

G450 HYDRAULIC SYSTEM

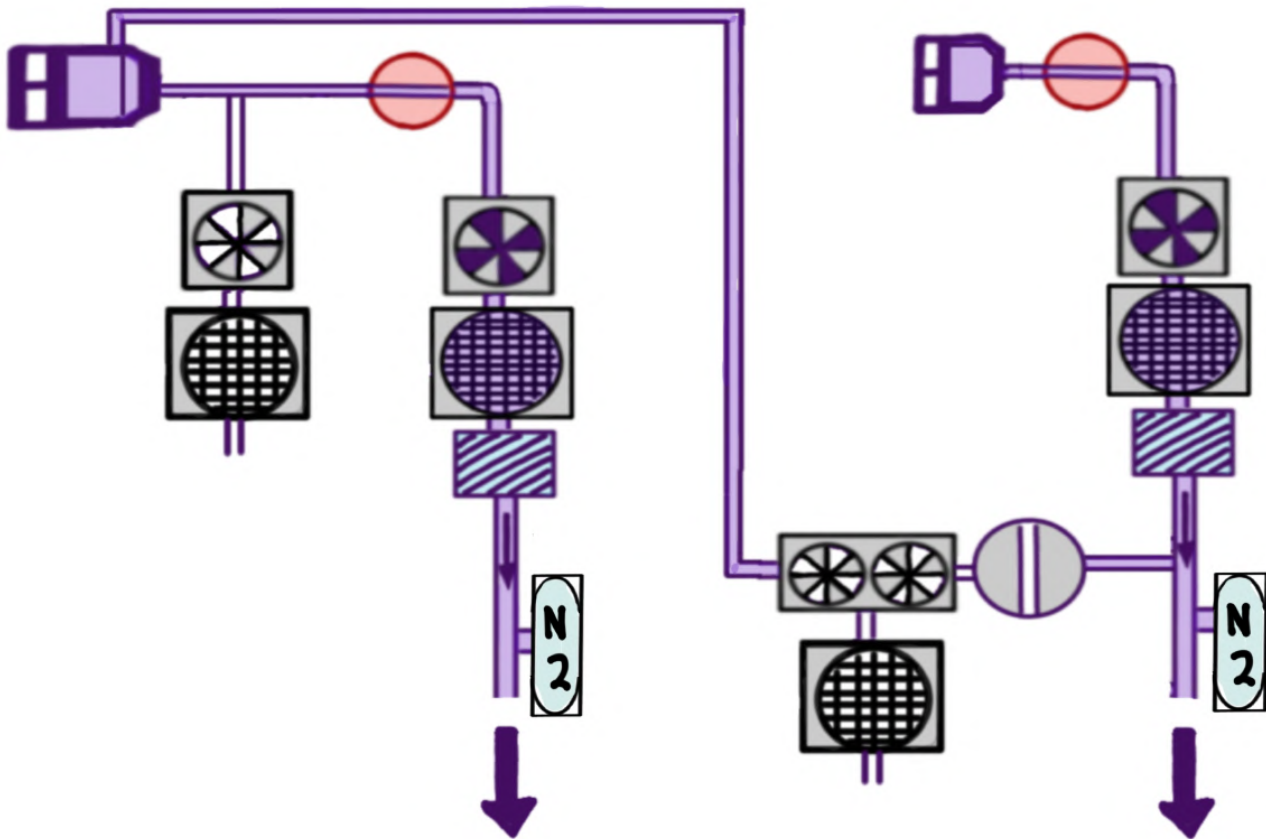

For study purposes only

The **Hydraulic** System is about the STORAGE AND DELIVERY of hydraulic fluid (Skydrol) UNDER high PRESSURE TO ACTUATE VARIOUS SYSTEMS

Two (2) MAIN SYSTEMS

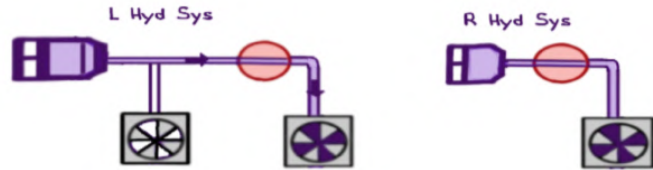

SUPPORTED by Two (2) sub-systems

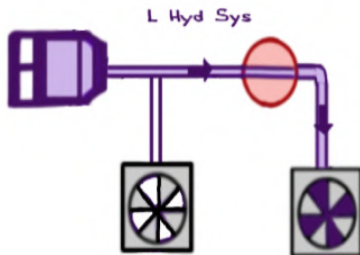
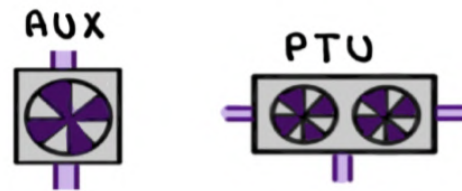

FLY



LAND

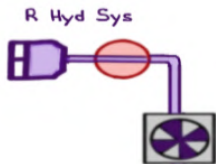

FLY

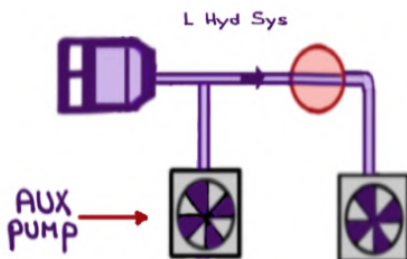

LAND MX



HYDRAULIC SYSTEM COMPONENTS



RESERVOIR: To store fluid

- COMPRESSED by bootstrap to PREVENT hydraulic pump CAVITATION
- LOCATED in THE TAIL COMPARTMENT
- SYSTEM MUST BE PRESSURIZED for ACCURATE quantity checks

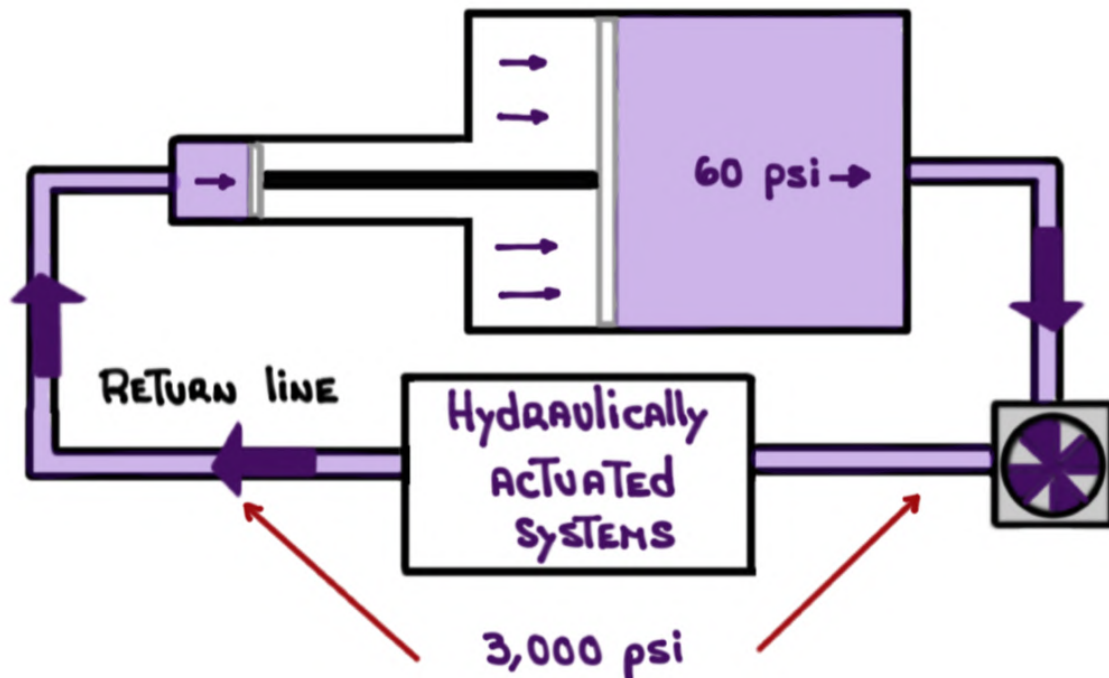

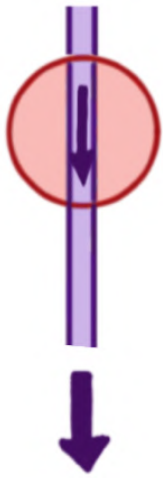

Shutoff valve: To shut off hydraulic fluid to the engine in the event of engine **FIRE** or failure

- Located in the tail compartment and activated via **FIRE HANDLES**



Pump: To pressurize system

- Engine-driven pump
- Located in the engine's gearbox
- **3,000 ± 300** Psi



Filter Manifold: To filter hydraulic fluid and control direction of flow

- Located in the tail compartment
- Contains several Differential Pressure Indicators (DPIS)

Hydraulic fluid-To-fuel HEAT EXCHANGER:

To **COOL** hydraulic fluid AND To **WARM** up cold fuel

- LOCATED IN THE **ONSIDE** fuel Hopper
- **CONTINUOUS** flow

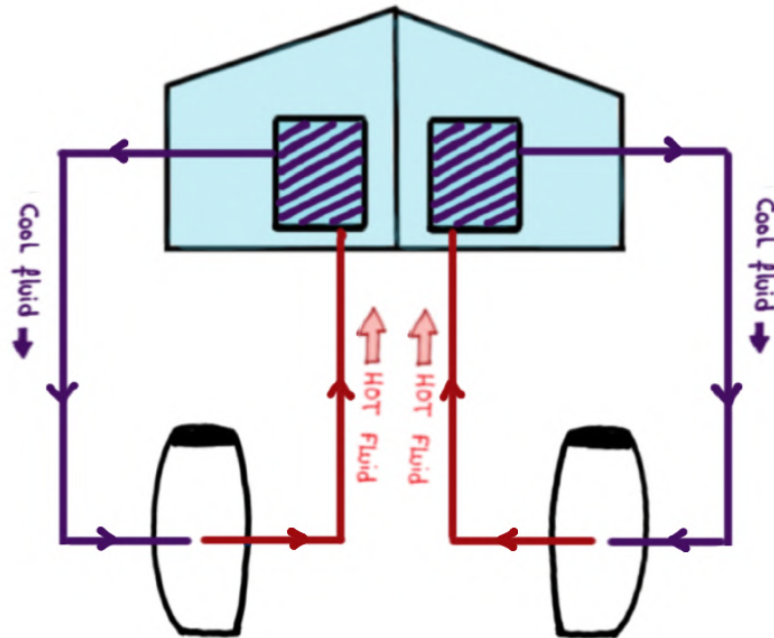

ACCUMULATOR: To absorb system shocks

- PRE-CHARGED To **1,200** Psi @ **70°F**
- Absorbs fluid shocks within THE SYSTEM
- SERVICED with Nitrogen
- LOCATED IN THE TAIL COMPARTMENT



To Hydraulically-powered
SYSTEMS

Differential Pressure Indicators (DPI)

- INSPECTED FOR CONDITION (flushed vs EXTENDED)
DURING THE EXTERIOR PREFLIGHT INSPECTION

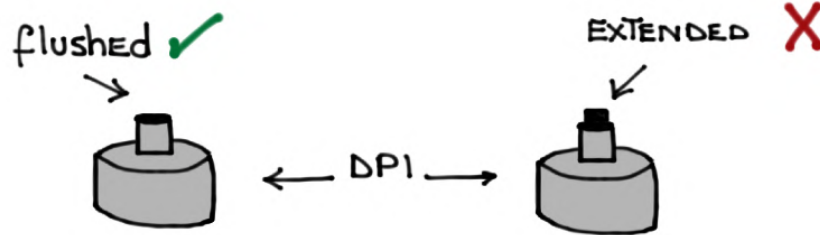

- THERE ARE TEN (10) DPIs

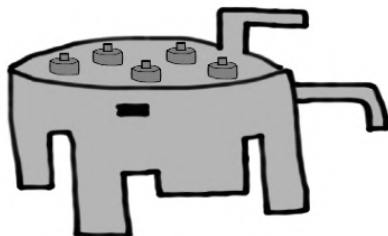

L Hydraulic System
MANifold
(5) DPIs

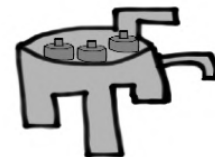

R Hydraulic System
MANifold
(3) DPIs



PTU
MANifold
(1) DPI



AUX PUMP
MANifold
(1) DPI

- AN EXTENDED DPI INDICATES A FILTER BYPASS WHICH REQUIRES A MAINTENANCE ACTION PRIOR TO FLIGHT BY AN AIRCRAFT MAINTENANCE TECHNICIAN OR A TRAINED AND AUTHORIZED INDIVIDUAL

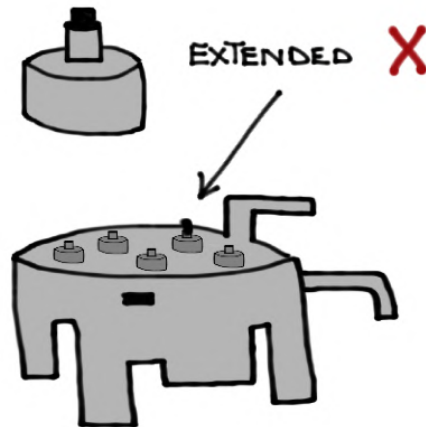

- THE ONLY DPI THAT CAN BE RESET BY THE CREW IS THE PTU DPI
(AFM - EXTERIOR PREFLIGHT INSPECTION)



If EXTENDED:

- ① RESET DPI
- ② MAKE AN ENTRY IN THE TECHLOG
- ③ CONTINUED OPERATION IS PERMITTED FOR 50 HOURS

L Hydraulic System

- Independent and isolated from Right Hydraulic System
- Supported by The AUX pump and PTU sub-systems

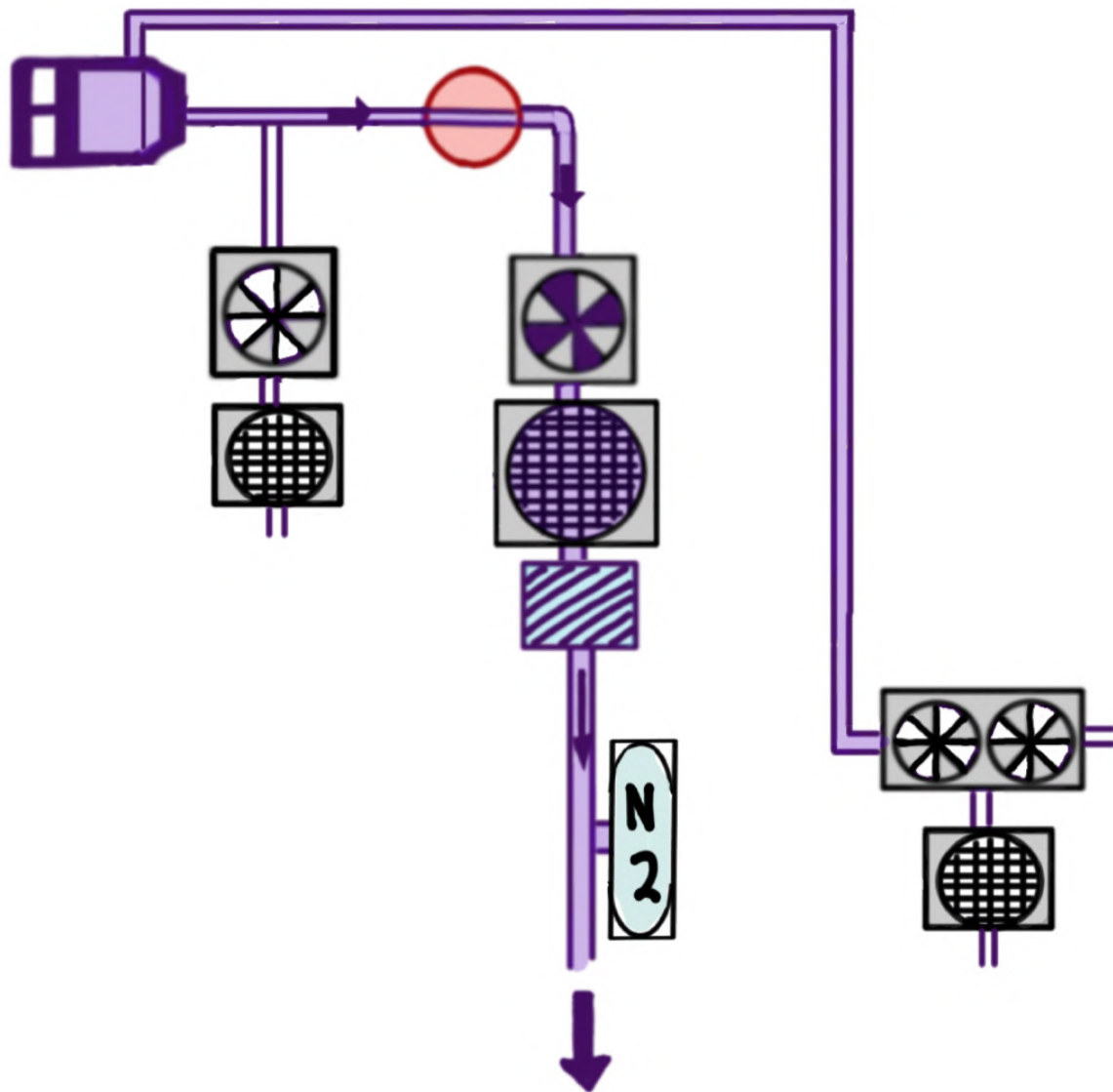

To Hydraulically - powered
Systems

- Total capacity: 18.4 gallons
- Largest Reservoir: 6.4 gallons
- DUAL CHAMBER: 4.4 + 2.0
- CONSIDERED full AT: 2.8 gallons
- MUST BE PRESSURIZED FOR ACCURATE READING
- Supplies hydraulic fluid To:

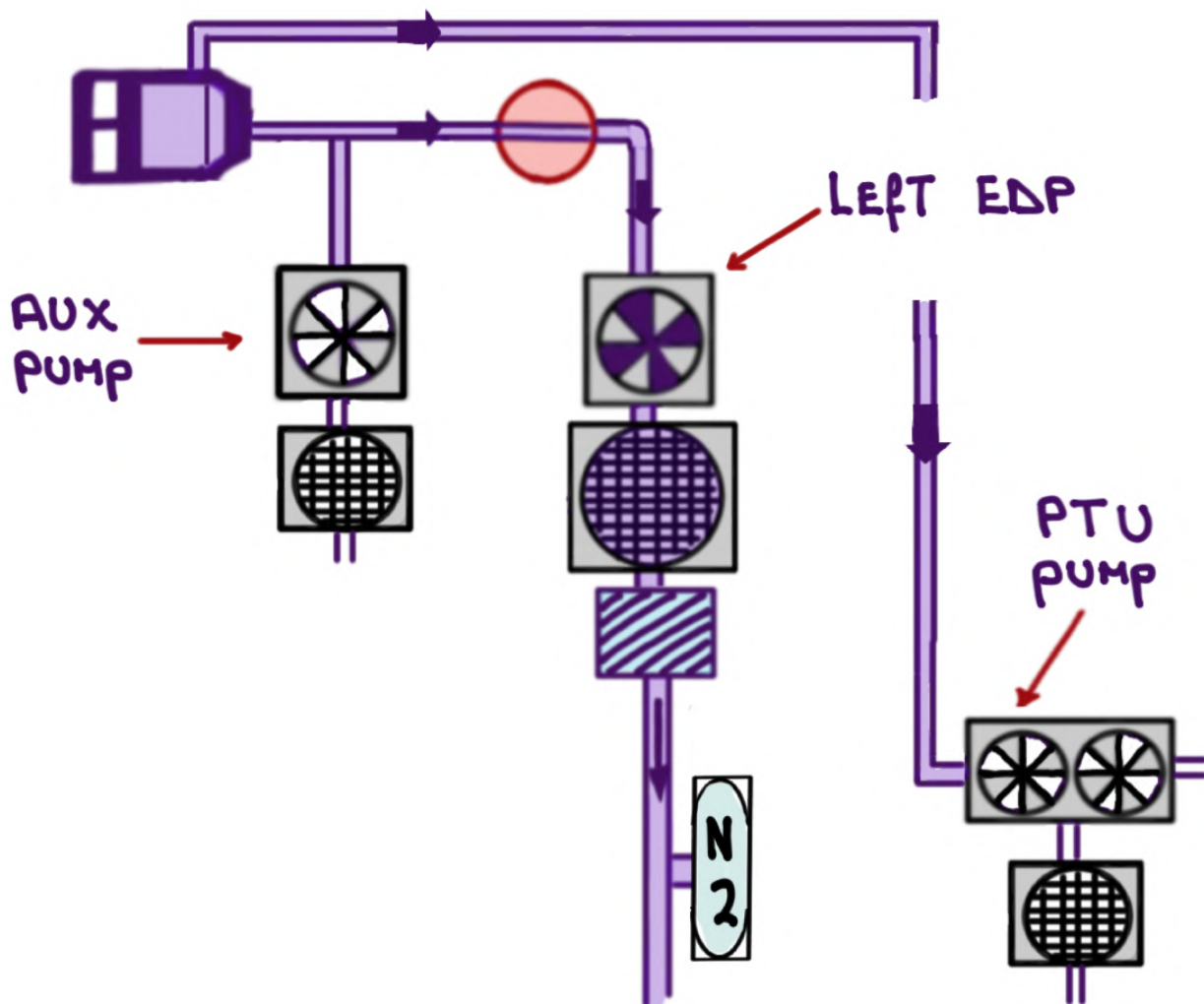

- FIVE (5) FILTERS

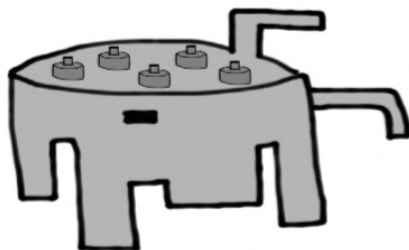

L Hydraulic System
Manifold
(5) DPis

- POWERED by THE LEFT ENGINE-DRIVEN PUMP (EDP)

- MOUNTED ON THE ENGINE GEARBOX

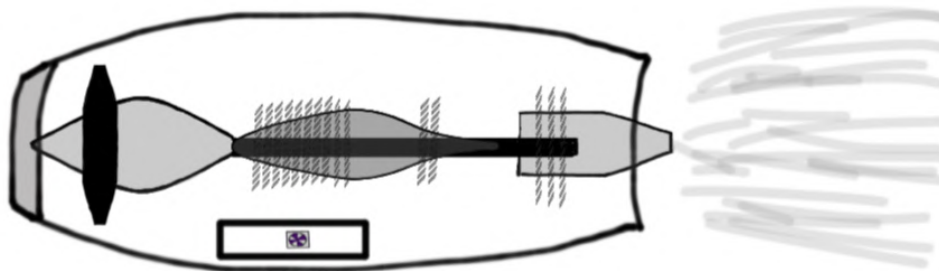

- CONSTANT PRESSURE, VARIABLE VOLUME PUMP
- PRESSURIZES hydraulic fluid To $3,000 \pm 300$ PSI
- FLOW RATE VARIES BASED ON POWER SETTING
 $10.5 - 21.3$ gallons/minute (idle to TAKEOFF power)

• FAILURE of EDP RESULTS IN THE loss of:

① LEFT THRUST REVERSER

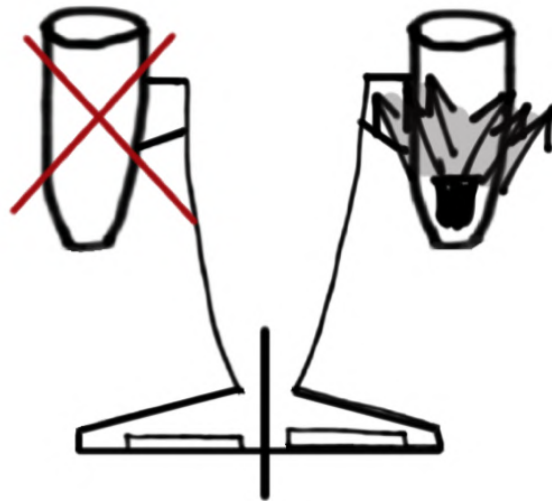

② REDUNDANT flight controls AND YD 1

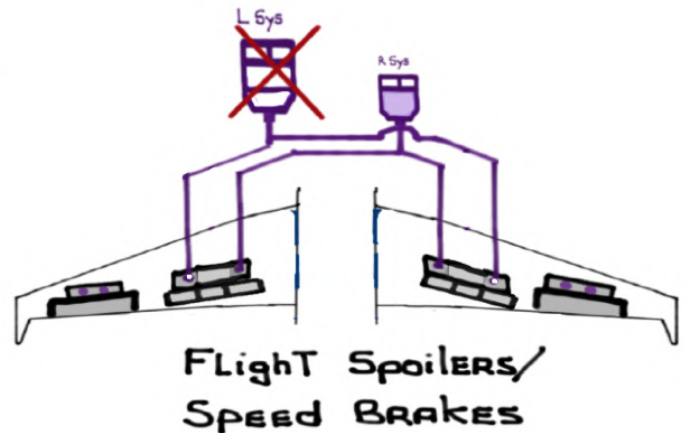
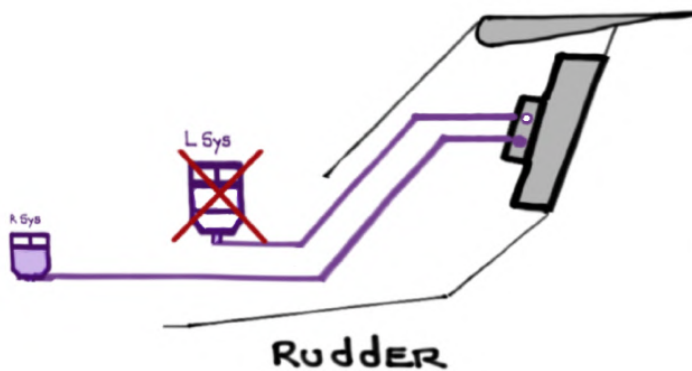
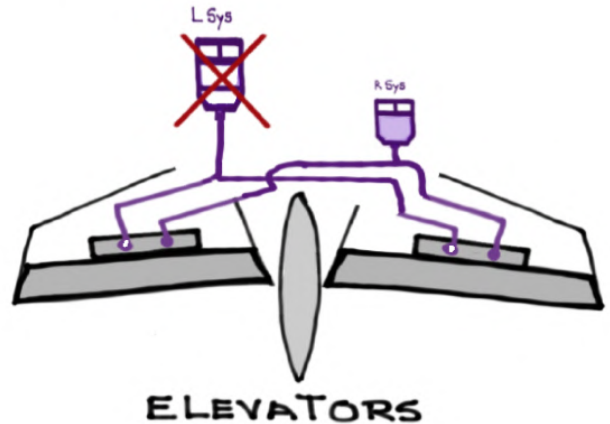
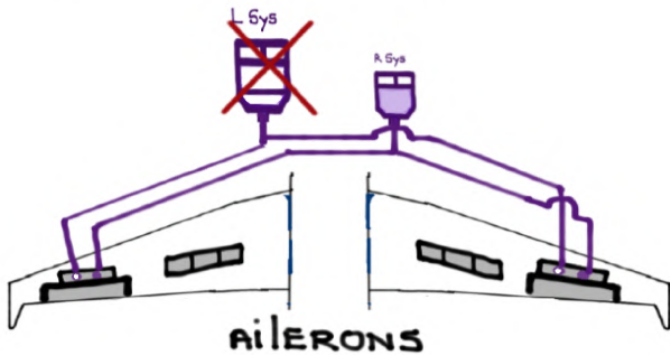

R Hydraulic System

- INDEPENDENT AND ISOLATED FROM LEFT Hydraulic System

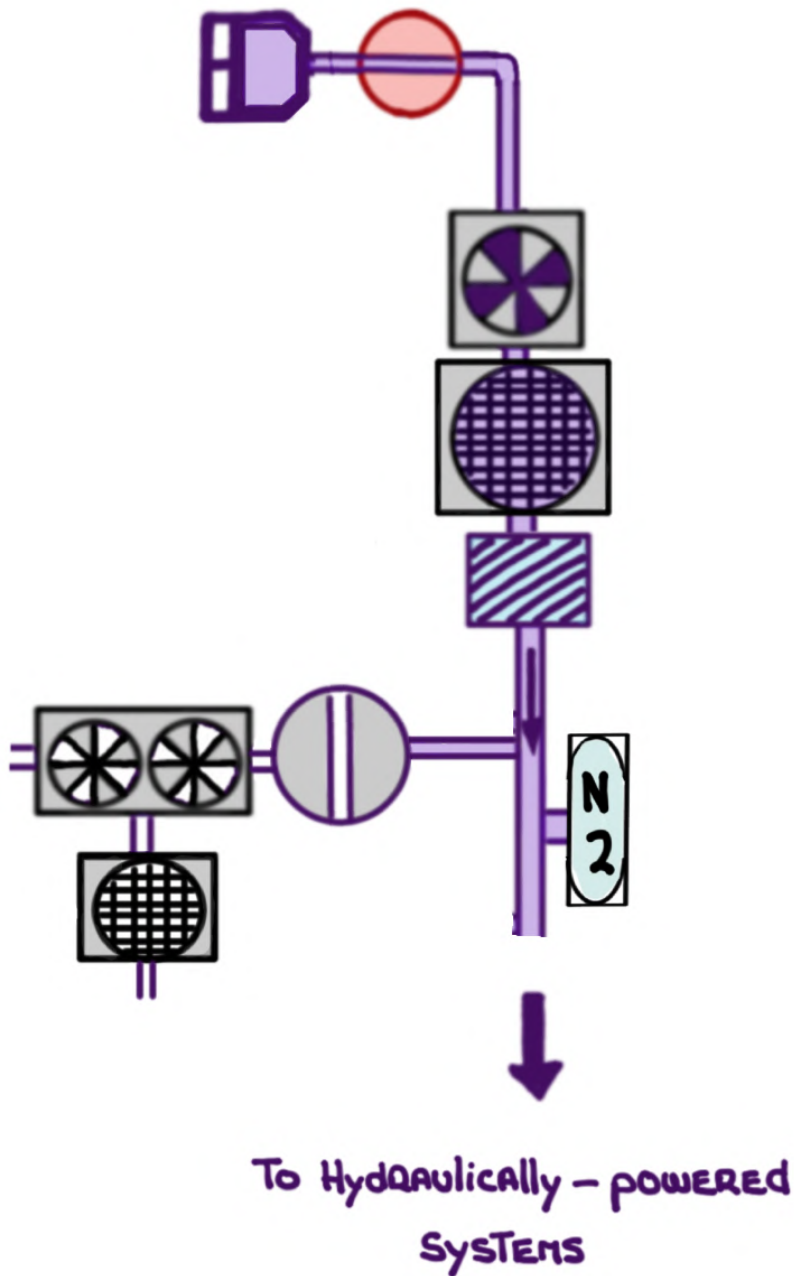

- TOTAL CAPACITY: 7.5 gallons
- SMALLEST RESERVOIR: 1.5 gallons
- CONSIDERED FULL AT: 0.8 gallons

MUST BE PRESSURIZED FOR ACCURATE READING

Supplies hydraulic fluid To RIGHT EDP

Supplies PRESSURIZED hydraulic fluid To PTU MOTOR

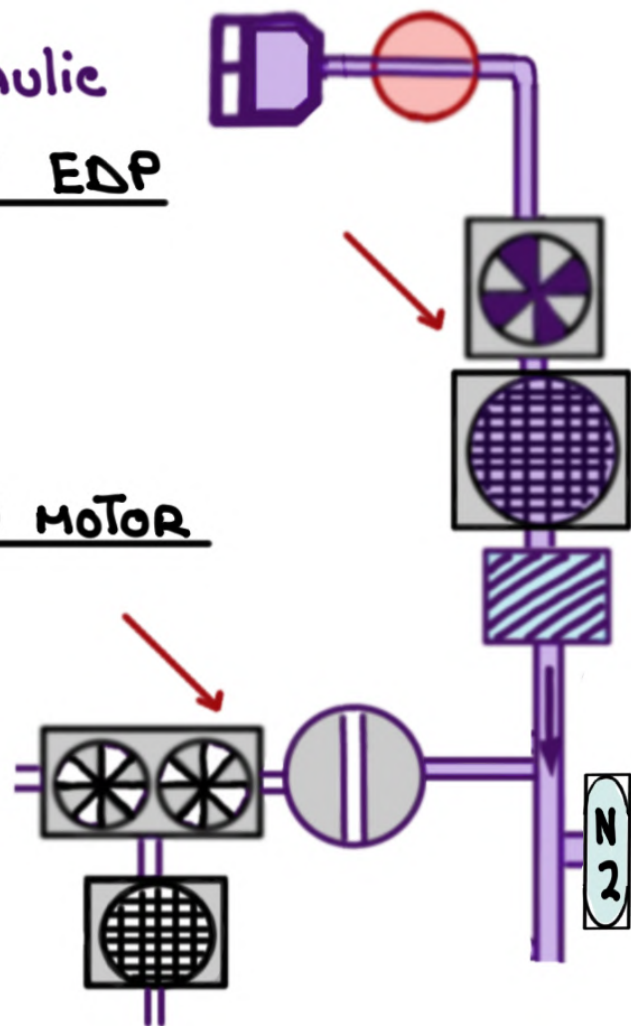

- THREE (3) FILTERS

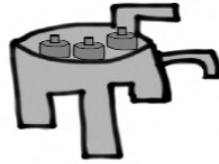

R Hydraulic System
Manifold
(3) DPLs

- POWERED by THE Right ENGINE-DRIVEN pump (EDP)

- MOUNTED ON THE ENGINE GEARBOX

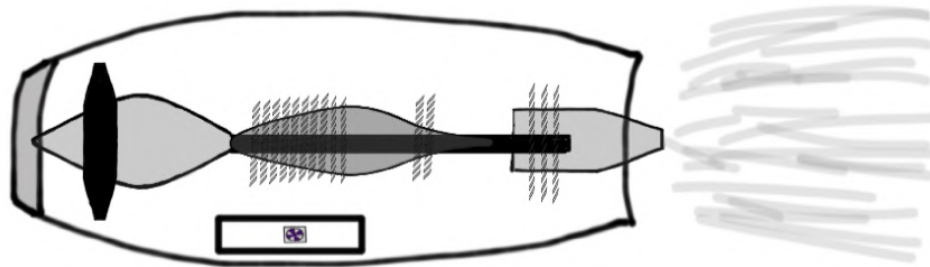

- CONSTANT PRESSURE, VARIABLE VOLUME PUMP
- PRESSURIZES hydraulic fluid To $3,000 \pm 300$ PSI
- FLOW RATE VARIES BASED ON POWER SETTING
 $10.5 - 21.3$ gallons/minute (idle to TAKEOFF POWER)

• FAILURE of EDP RESULTS in THE loss of:

① Right Thrust REVERSER

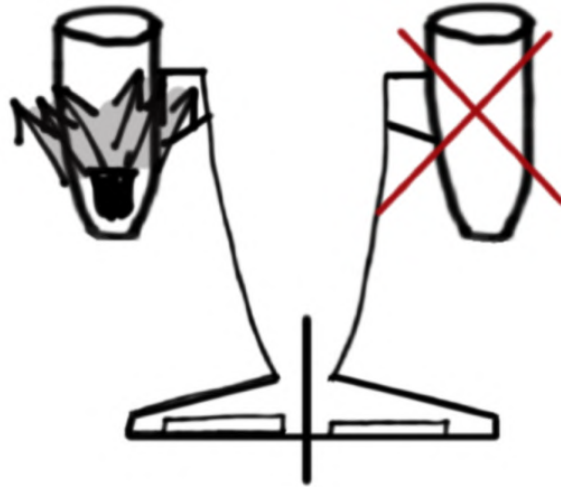

② REDUNDANT flight controls AND YD 2

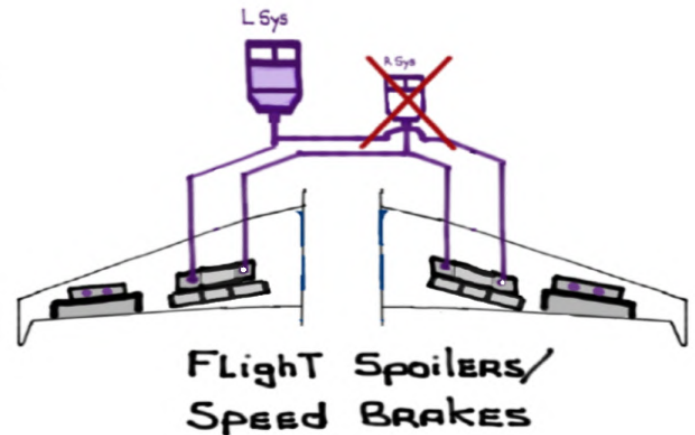
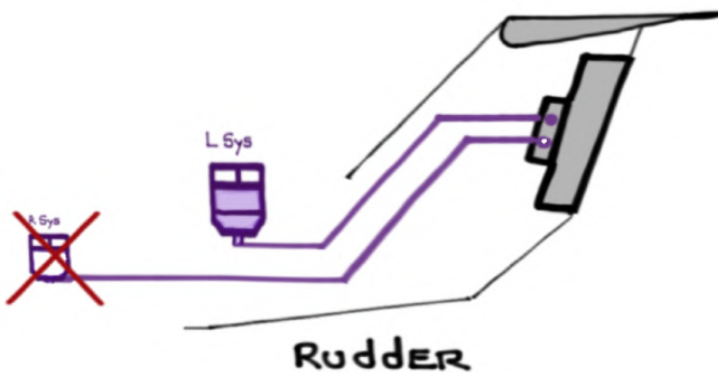
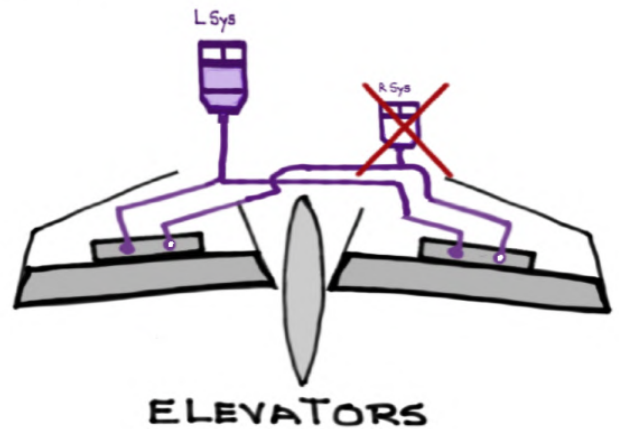
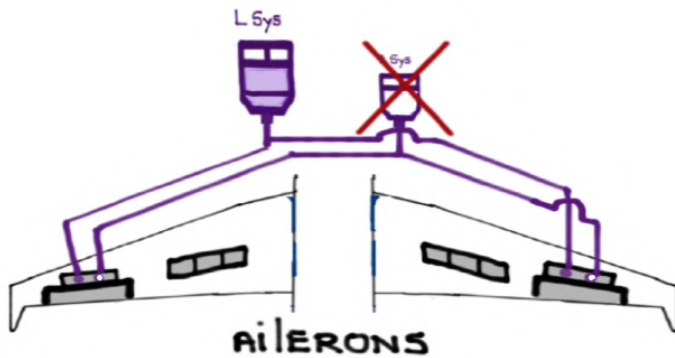

Auxiliary (AUX) Hydraulic System

- Supplements The LEFT Hydraulic System

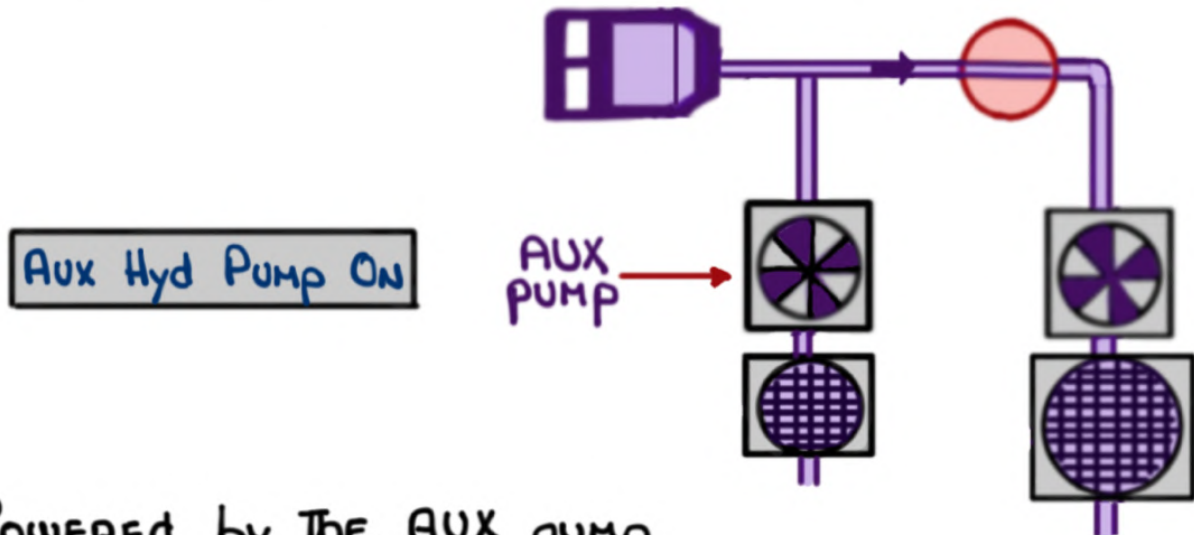

- Powered by the AUX pump

- The  pump is located in the tail compartment (left side)



• Electrically powered by L ESS DC bus

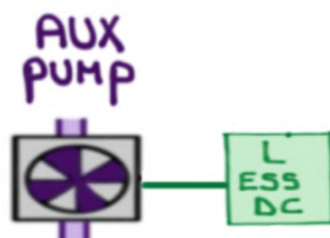

- Uses LEFT SYSTEM fluid
- OPERATES EITHER AUTOMATICALLY OR MANUALLY
- 3,000 Psi @ Two (2) gallons PER MINUTE

- RESERVOIR is physically located within THE LEFT HYDRAULIC SYSTEM RESERVOIR

- RESERVOIR capacity: 2.0 gallons

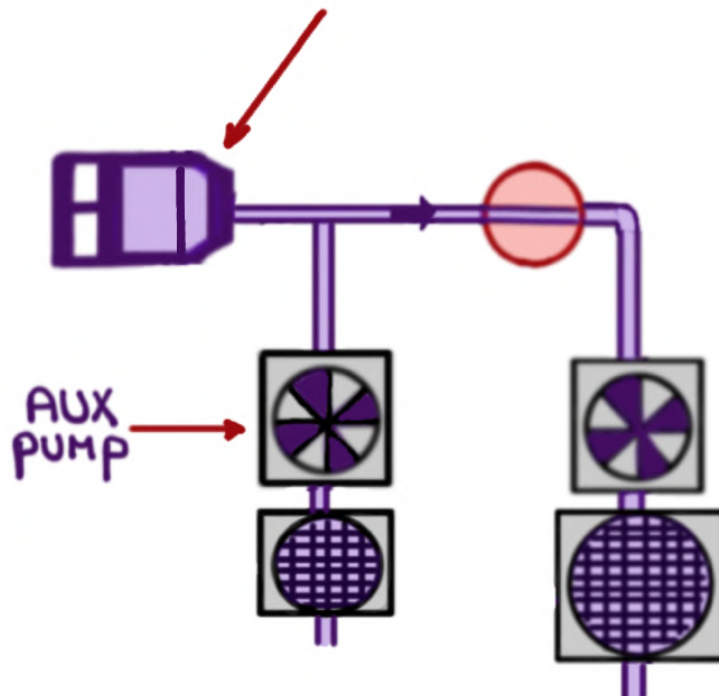

- OPERATES THE MAIN ENTRANCE DOOR (MED) AND PARKING BRAKE ACCUMULATOR by itself

- CAPABLE OF POWERING:

① MAIN ENTRANCE DOOR (MED)



② FLAPS

Flap 0

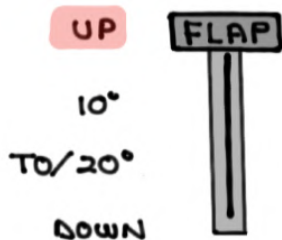
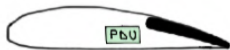

Flap 10

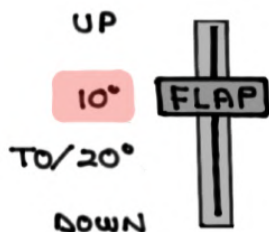
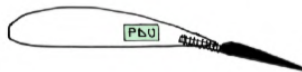

Flap 20

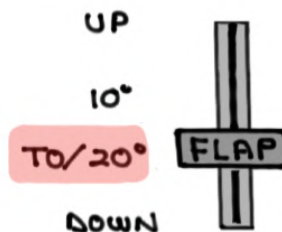
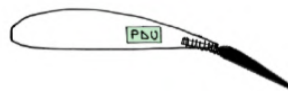

Flap 39

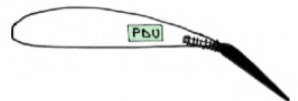

③ BRAKES

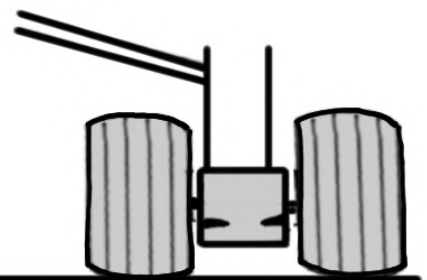
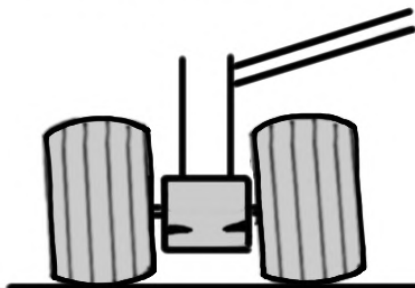

FUNCTIONS ON THE **GROUND**:

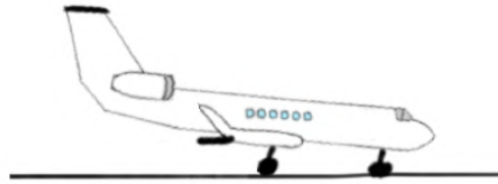

① Auto latch feature (BRAKE PEDAL APPLICATION, AND low **HYDRAULIC PRESSURE**)

- WOW **GROUND** AND BRAKE PEDAL APPLICATION $> 10^\circ$

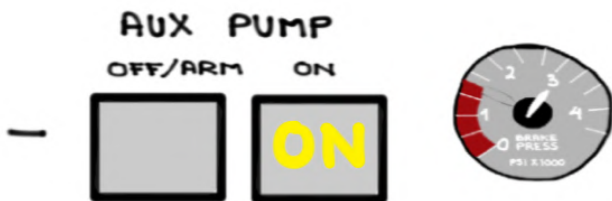
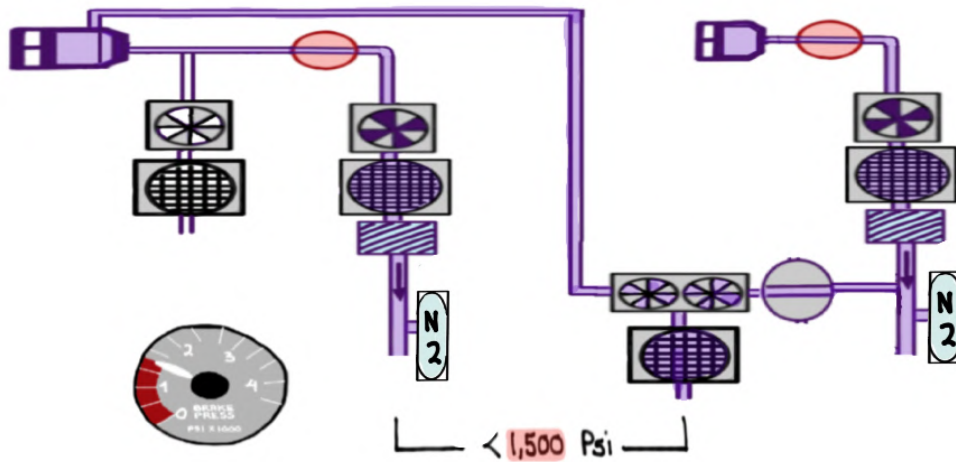

② MAINTENANCE OPERATIONS (gear ops while on jacks)

③ PREFLIGHT INSPECTION: gear doors opening and closing

POWER TRANSFER UNIT (PTU)

- Back up To The LEFT Hydraulic System ENGINE-DRIVEN pump (OPERATIONAL REDUNDANCY)

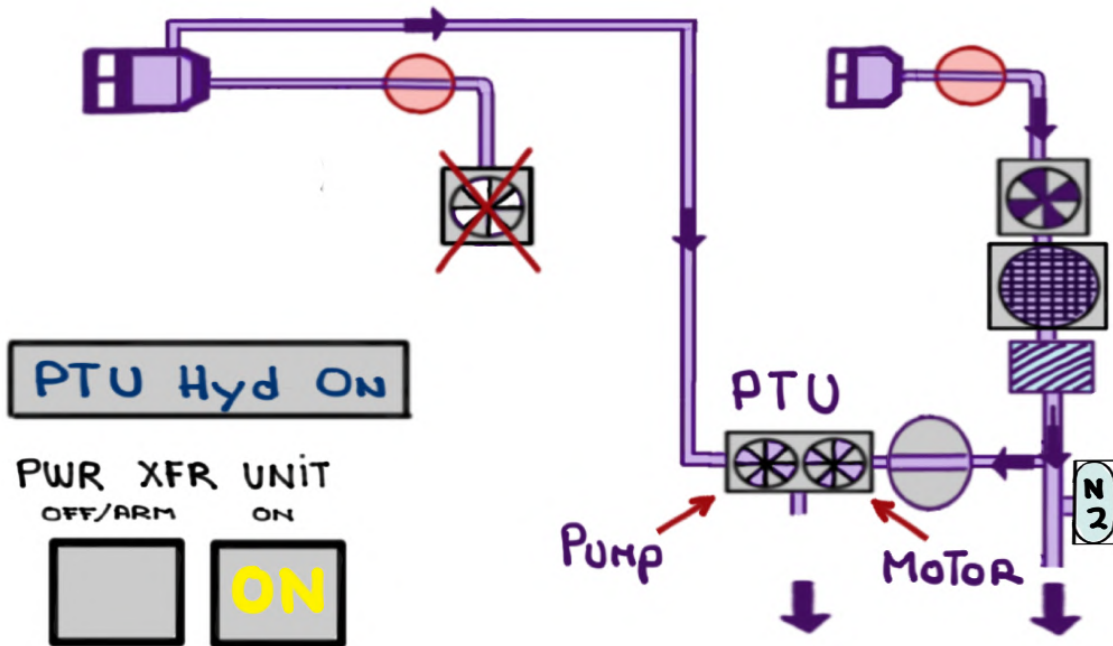

- The  is a MOTOR/PUMP ASSEMBLY

The MOTOR is driven by RIGHT SYSTEM PRESSURIZED fluid. The pump is driven by THE MOTOR AND ITS job is TO PRESSURIZE LEFT SYSTEM fluid

- IT COMES ON AUTOMATICALLY if L Hydraulic System PRESSURE is < 1,500 PSI

- IT CANNOT ACTUATE:

LEFT THRUST REVERSE

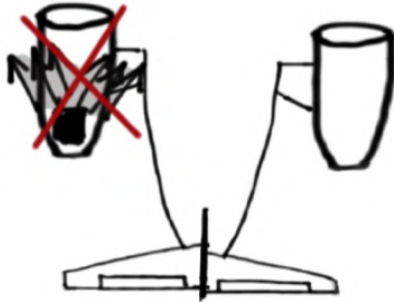

FLIGHT CONTROLS

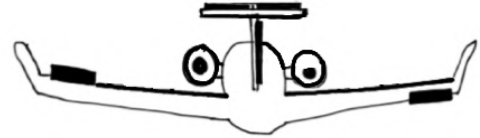

- The  CANNOT OPERATE WITHOUT:

▶ L HYDRAULIC SYSTEM FLUID

▶ R HYDRAULIC SYSTEM FLUID AND PRESSURE

- The  IS PREVENTED FROM COMING ON AUTOMATICALLY IF:

L Hyd Sys



< 1.0 g

R Hyd Sys



> 104 °C



PWR XFR UNIT
OFF/ARM ON

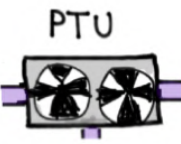

- The  is located in the Tail compartment (Right side)

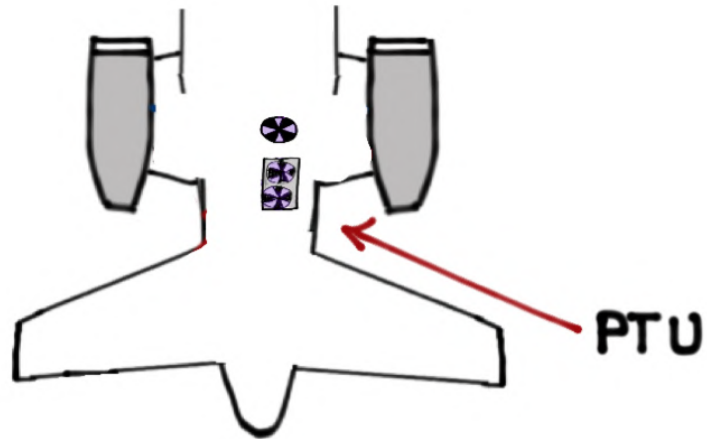

- 10 gallons/minute @ 3,000 Psi + 300/-400 Psi

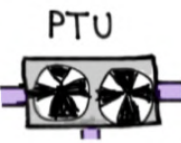
- The  helps retract the landing gear following left engine failure after V₁ (regulatory requirement)

L Engine Fail

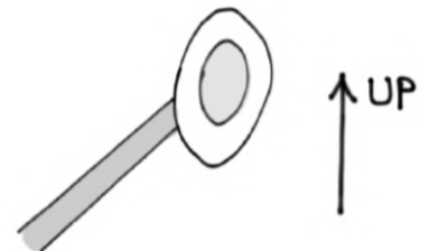
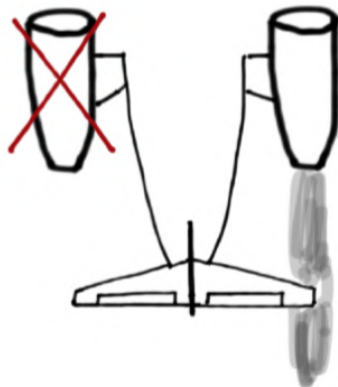

- The  can power the HMG **HMG Switch ON**

- Pulling The **LEFT FIRE HANDE** DOES NOT shut off The supply of LEFT Hydraulic System fluid To The 
PTU

W **L ENGINE FIRE** **W**

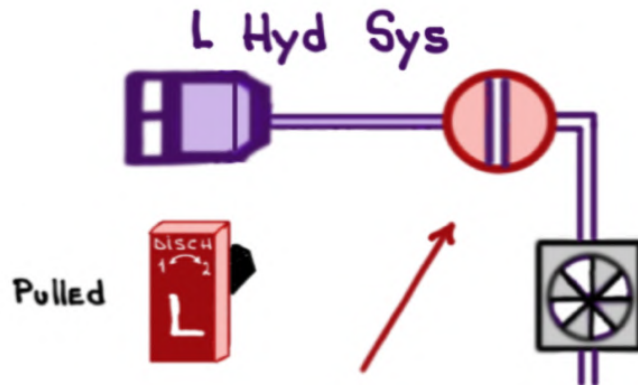

Shutoff VALVE
CLOSED

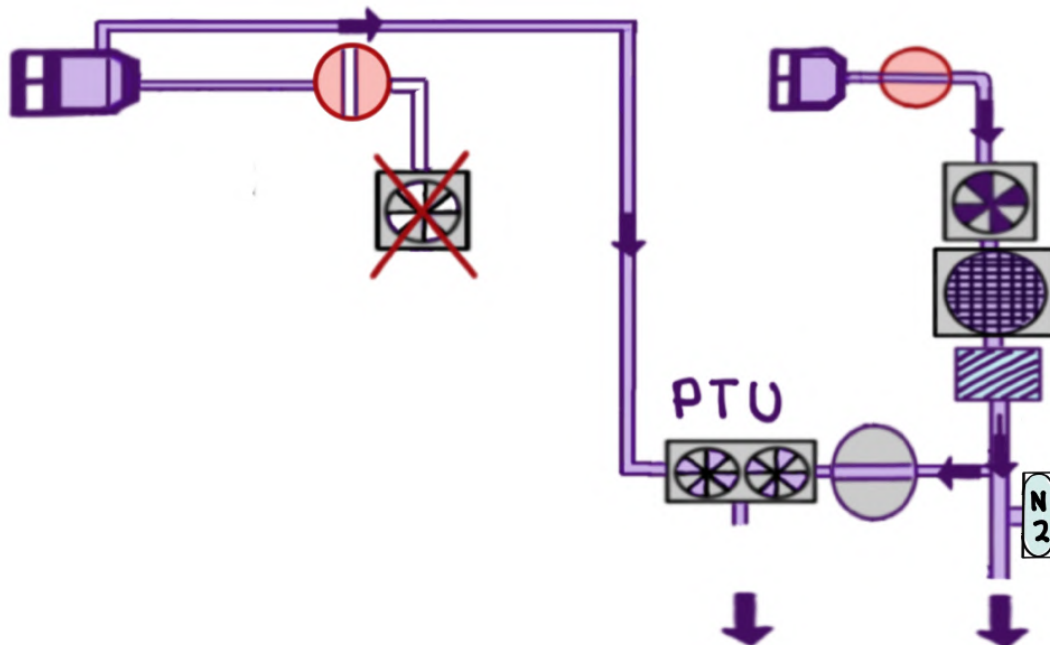

HYDRAULIC MOTOR GENERATOR

- The Hydraulic Motor Generator (HMG) is a backup **AC** GENERATOR

- The HMG is PART of THE Standby Electrical Power System

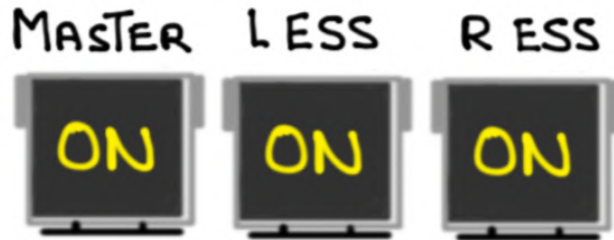

- The HMG is driven by:

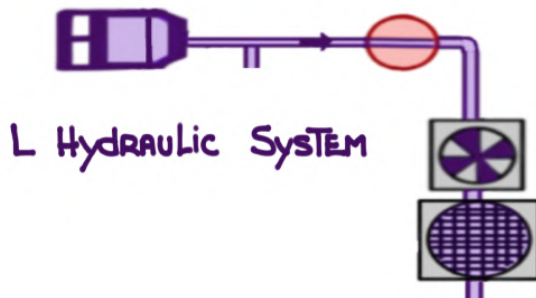

OR

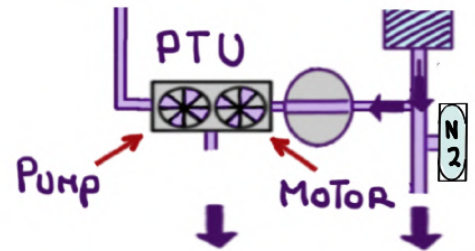

- The HMG POWERS:

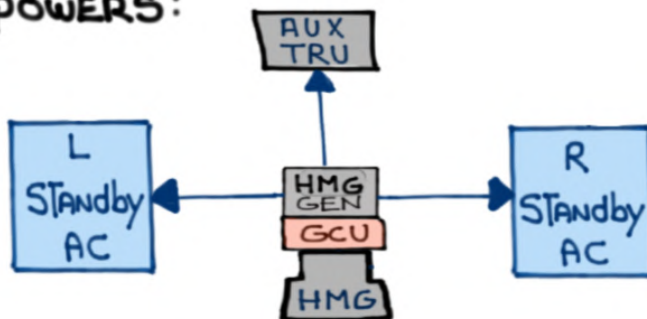

RATED AT **5** KVA \wedge PRODUCES: **115** VAC
400 HERTZ
3-PHASE

HMG Switch ON

- The HMG produces **AC** power in the event of a dual ~~L IDG~~ ~~R IDG~~ AND ~~APU GEN~~ failure

- The HMG is located in the tail compartment

- HMG operation is permitted only when normal **AC** power generation is not available

- The **AUX TRU** produces **DC** voltage and will power the **L ESS DC** **R ESS DC** buses when selected by the crew with a **TEN (10)** second interval between selections

- Speed brake deployment is OK as long as the handle is moved from stowed to fully extended in **THREE (3)** SECONDS OR MORE

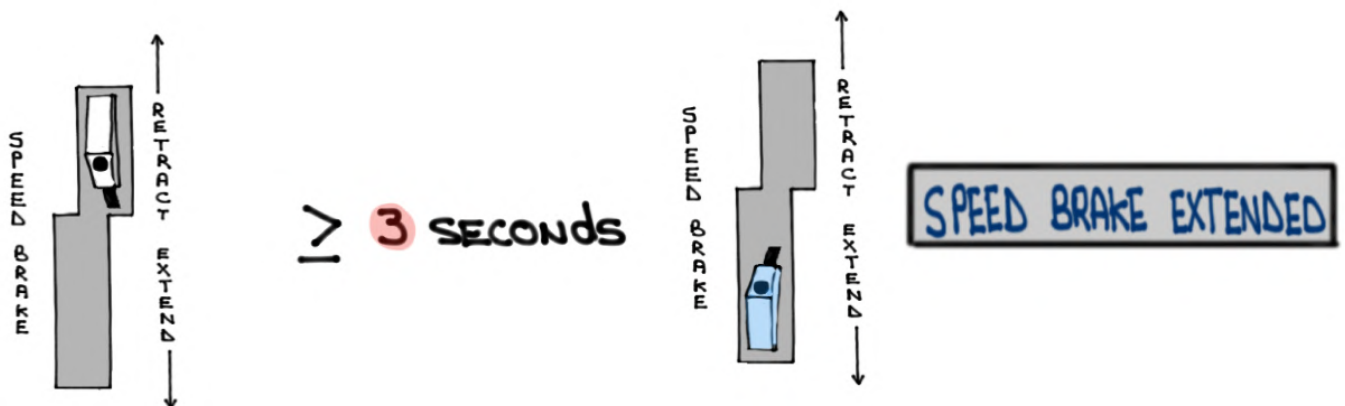

Hydraulic fluid To FUEL HEAT EXCHANGER

The Hopper Tanks CONTAIN THE Hydraulic fluid-To-FUEL HEAT EXCHANGERS

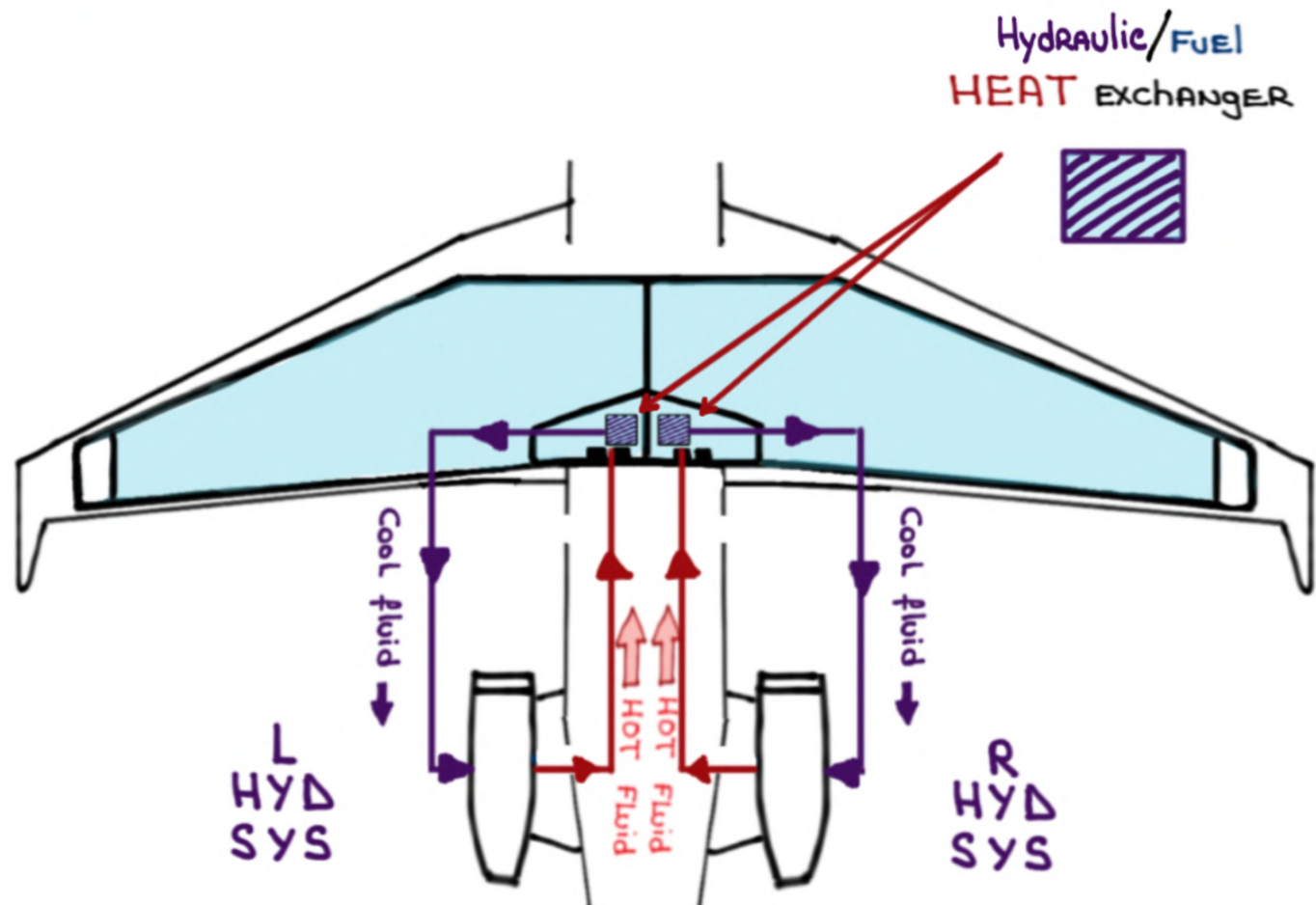

The HEAT EXCHANGER UNIT is inside THE ONSIDE fuel Hopper. **HOT** hydraulic fluid flows CONTINUOUSLY THROUGH THE HEAT EXCHANGER WITHOUT pilot input

HOT Hydraulic fluid is cooled while **COLD** fuel in THE Hopper is WARMED up

Hydraulic Shutoff Valves

① Fire Handles

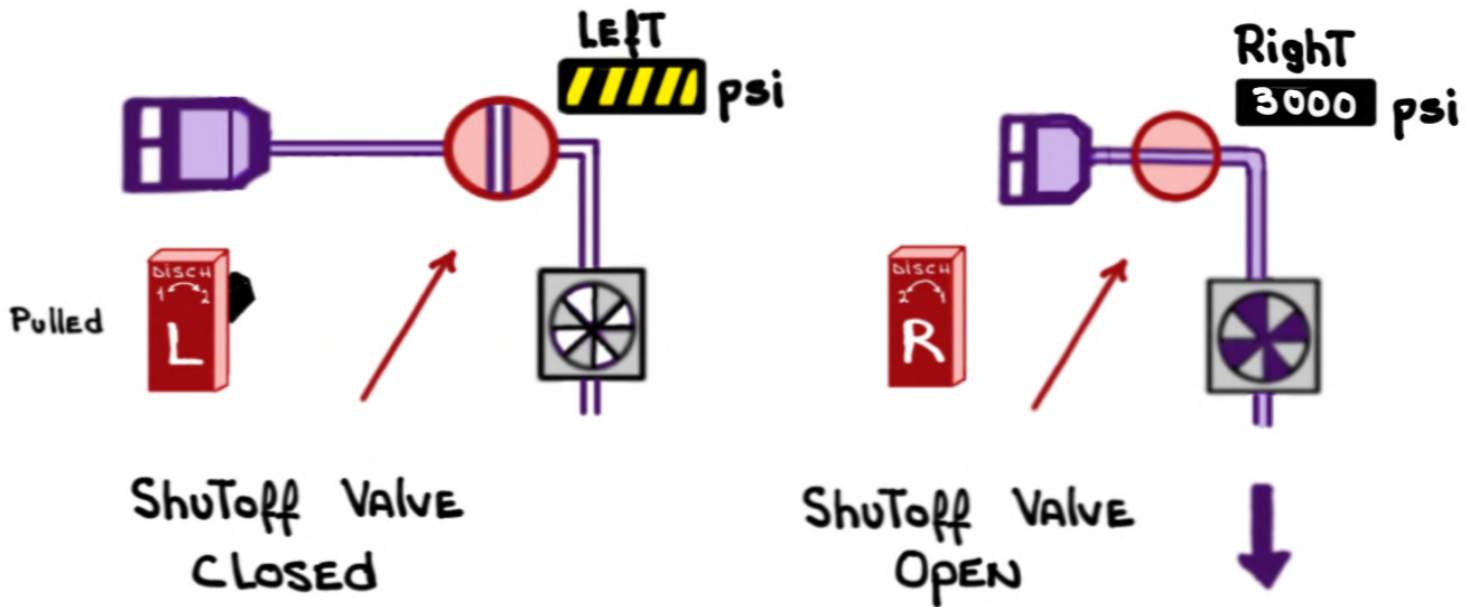

② The hydraulic shutoff valves are located in the tail compartment. They isolate the hydraulic fluid from the engine-driven pumps.

③ The valves are motor-operated and are energized only when the **Fire Handles** in the cockpit are pulled up

Hydraulic Boost Actuators

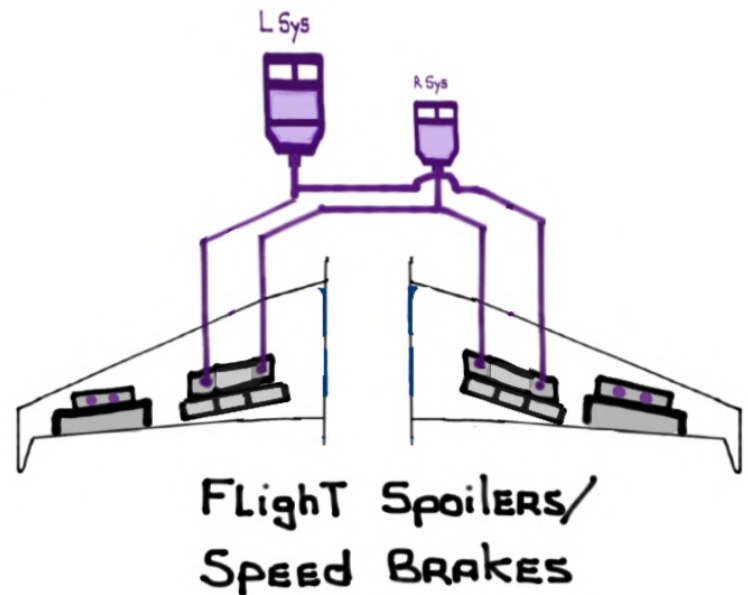
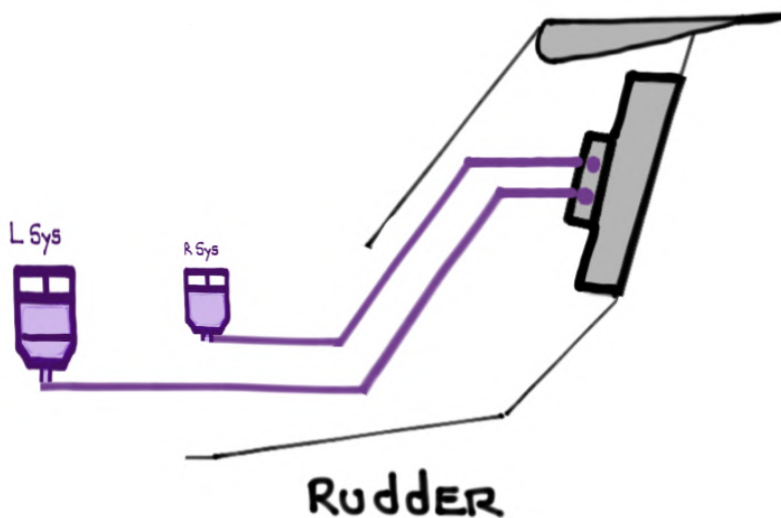
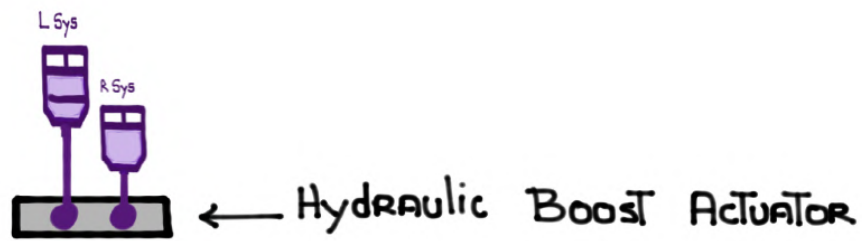
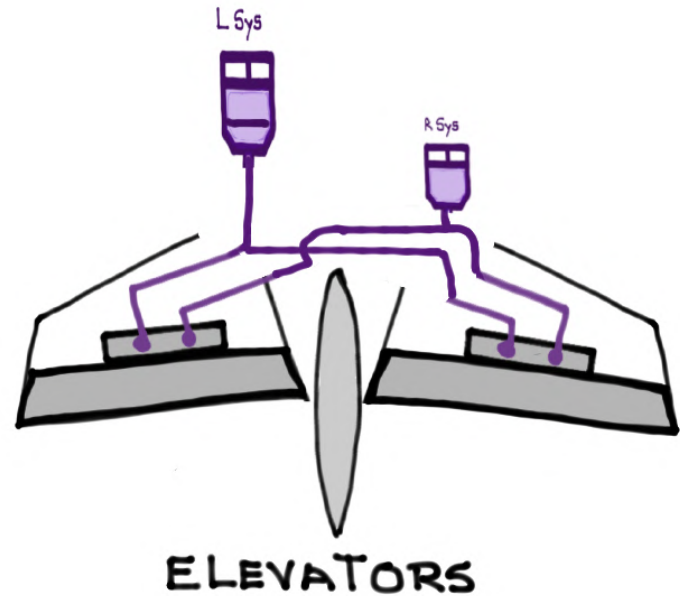
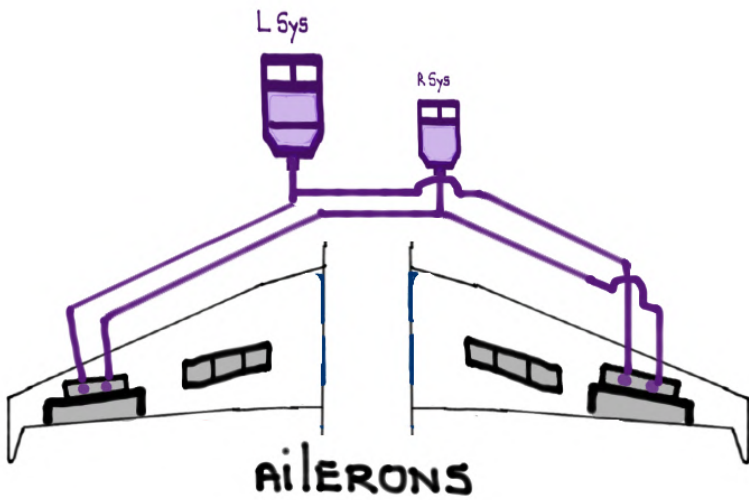

Hydraulic SYSTEM QUANTITIES/PRESSURES

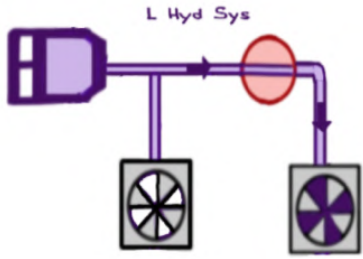

- TOTAL CAPACITY: 18.4 gallons
 - LARGEST RESERVOIR: 6.4 gallons
 - CONSIDERED full AT: 2.8 gallons
-

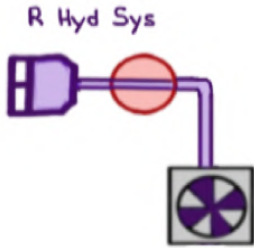

- TOTAL CAPACITY: 7.5 gallons
 - SMALLEST RESERVOIR: 1.5 gallons
 - CONSIDERED full AT: 0.8 gallons
-

L AND R Hyd Syst
PUMP OUTPUT

- 10.5 - 20.5 gallons PER MINUTE (idle - TAKEOFF)
 - 3,000 Psi \pm 300
-

AUX Hyd Syst
PUMP OUTPUT

- 2 gallons PER MINUTE
 - 3,000 Psi \pm 300
-

PTU Hyd Syst
PUMP OUTPUT

- 10 gallons PER MINUTE
 - 3,000 Psi + 300 / - 400
-

L AND R Hyd Syst ACCUMULATOR PRECHARGE

1,200 Psi @ 70°F

POWER PLANT FAILURE

The failure of EITHER ENGINE will RESULT in:

- ① LOSS of ENGINE-DRIVEN **Hydraulic** (EDP) pump
- ② If the LEFT ENGINE fails the PTU will TAKE OVER THE DUTIES of the INOPERATIVE EDP AS SOON AS **hydraulic** SYSTEM PRESSURE DROPS below **1,500** Psi

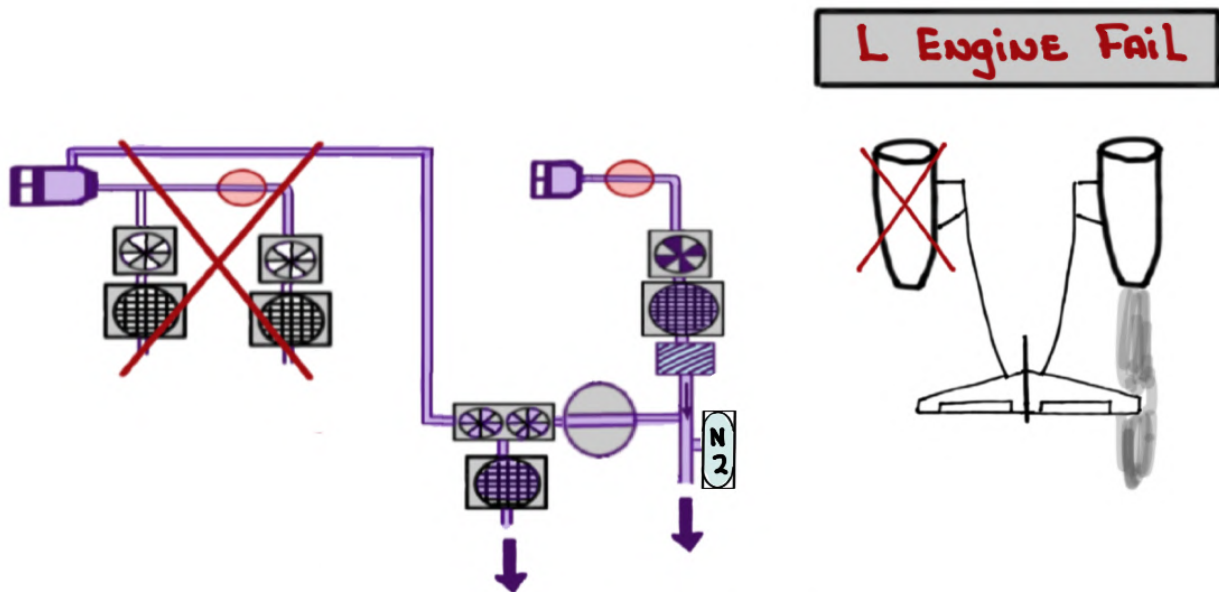

The following components will be lost:

- REDUNDANT **hydraulic** power to the flight controls
- LEFT THRUST REVERSER
- LEFT YAW DAMPER (YD1)

③ If the RIGHT ENGINE fails The Right Hydraulic System will be UNAVAILABLE.

The following components will be lost:

- REDUNDANT hydraulic power to the flight controls
- Right Thrust Reverser
- Right Yaw Damper (YD2)
- PTU

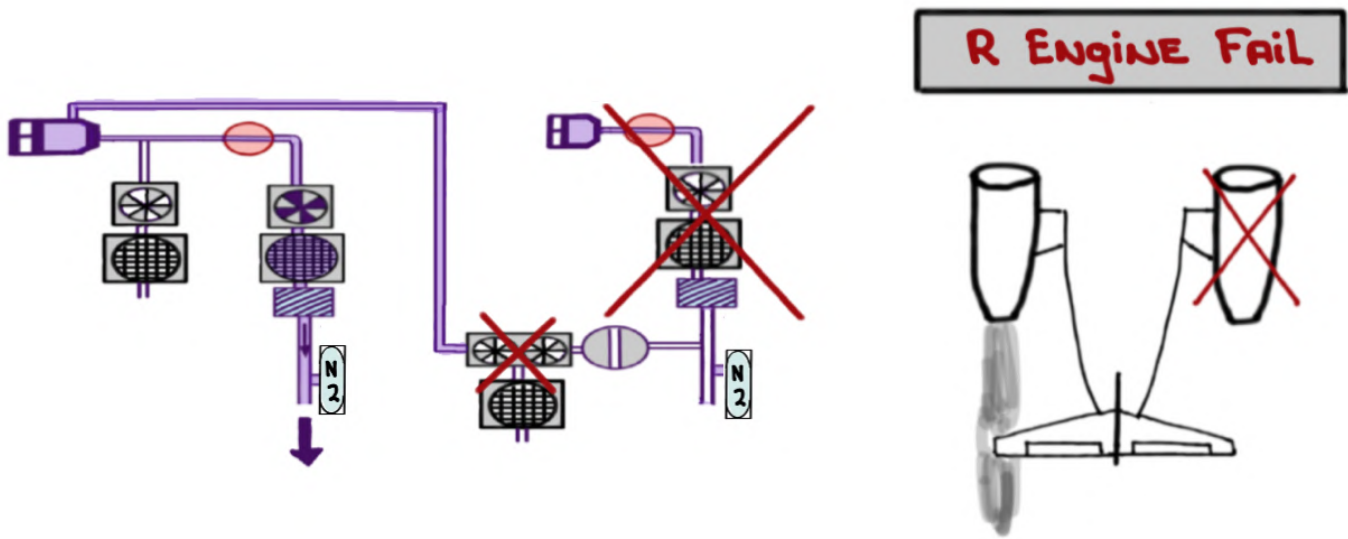

④ A **L ENGINE FAIL** OR **R ENGINE FAIL** inhibits

All OTHER MESSAGES ASSOCIATED WITH AN ENGINE FAILURE, SUCH AS:

L Hyd SYSTEM FAIL **R Hyd SYSTEM FAIL**

L Hyd System Fail

LEFT HYDRAULIC SYSTEM

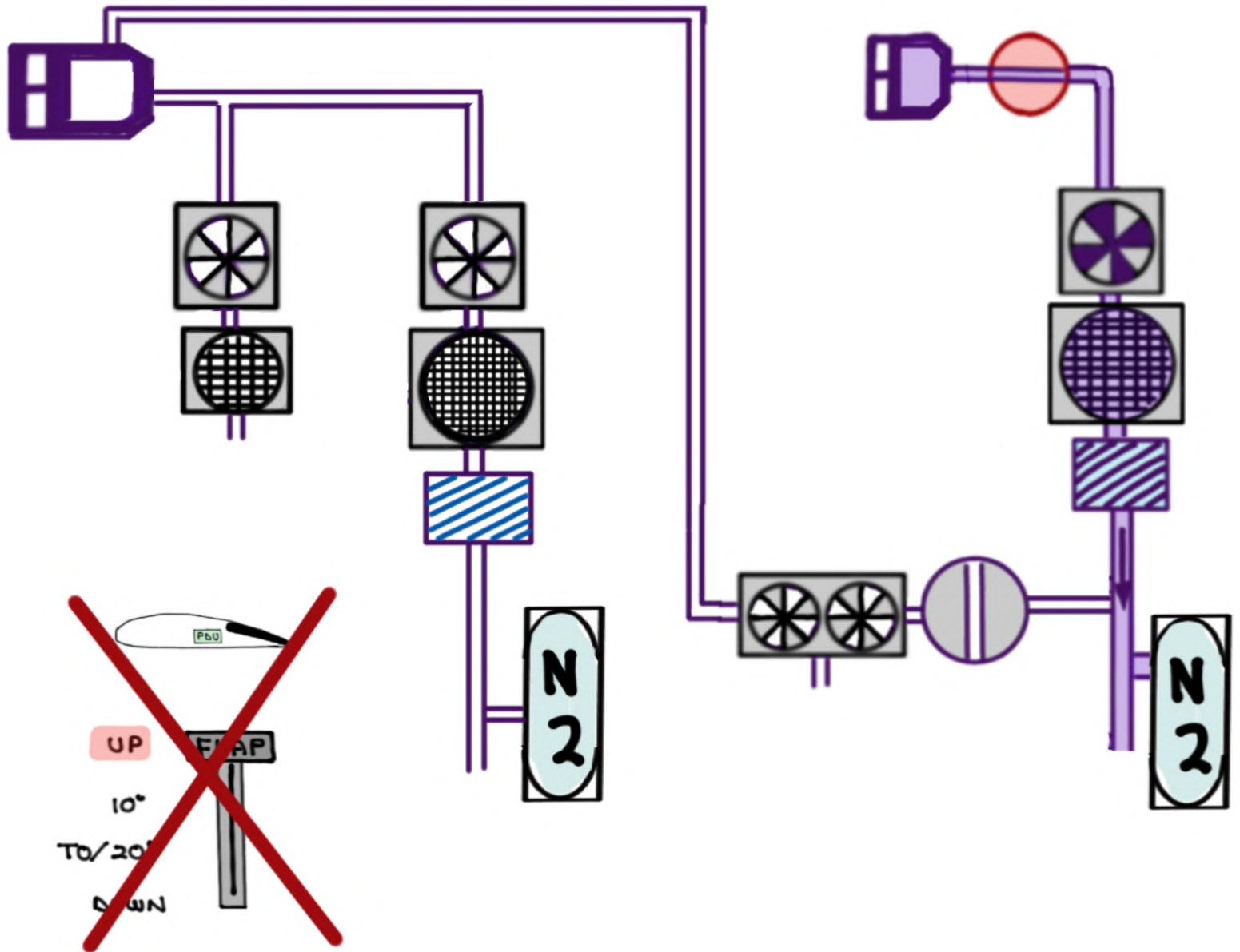

FLAPS ARE NOT AVAILABLE. With any flight control surface failure a "PAN, PAN" is required

REMINDER: these system notes are intended for study purposes only. Always refer to official Gulfstream manuals and other approved references when operating your aircraft.

NOTE: these system notes are updated from time to time and what is posted on Code450.com will always be the most recent version.

Questions, comments or errors...please do send me an email:
ivan@code7700.com

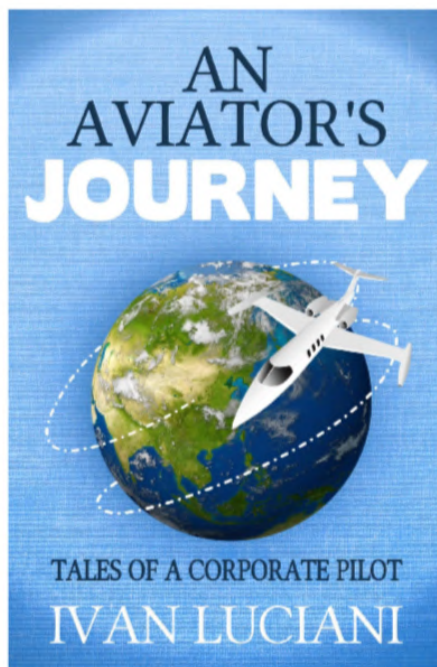

Thank you!