

G450 PNEUMATIC SYSTEM

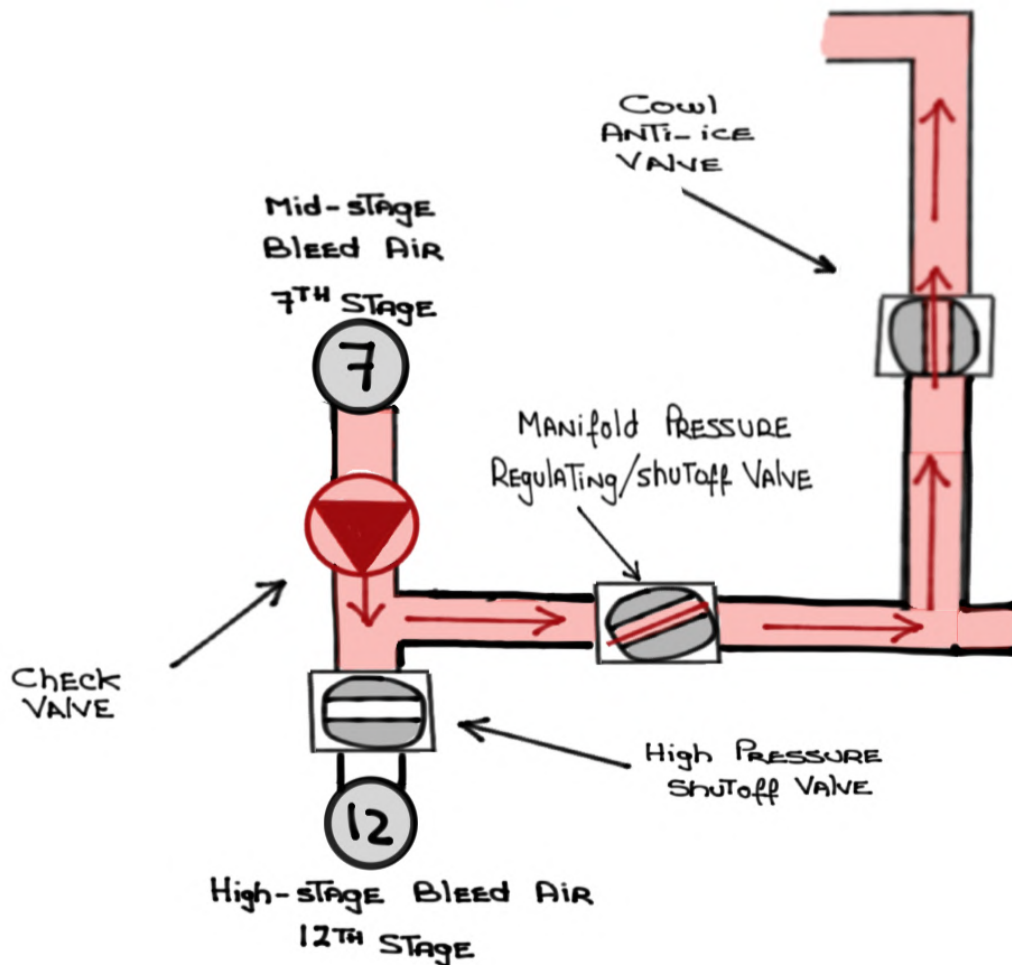

For study purposes only

The PNEUMATIC SYSTEM is about THE GENERATION of **High PRESSURE/TEMPERATURE** AIR FROM:

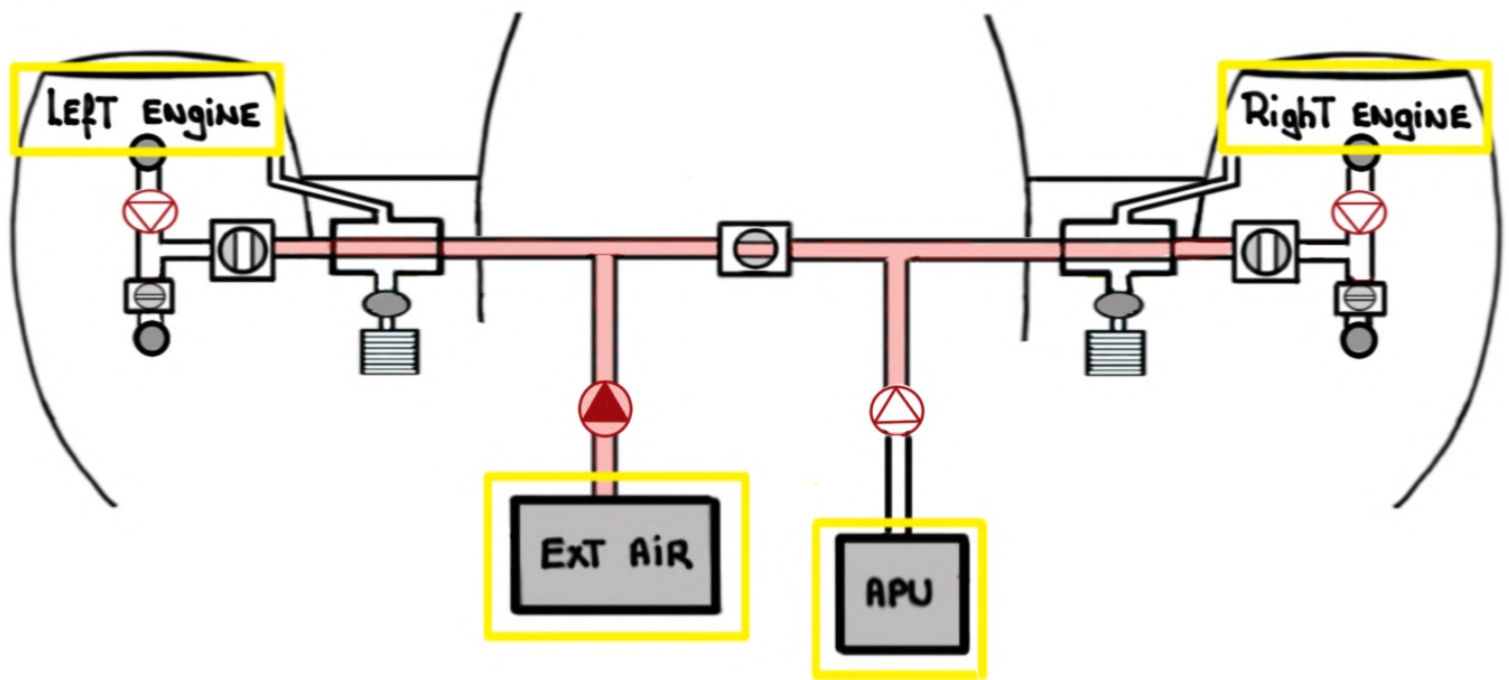

High **PRESSURE/TEMPERATURE** AIR is utilized by:

- ENGINE STARTING SYSTEM
- Cowl/Wing ANTI-ICE SYSTEMS
- AIR CONDITIONING/PRESSURIZATION SYSTEMS
- POTABLE WATER SYSTEM
- TAT PROBE AIRFLOW (**GROUND ONLY**)
- OTHER SYSTEMS

PNEUMATIC SYSTEM Sub-COMPONENTS

- BLEED AIR CONTROLLERS (BACs)

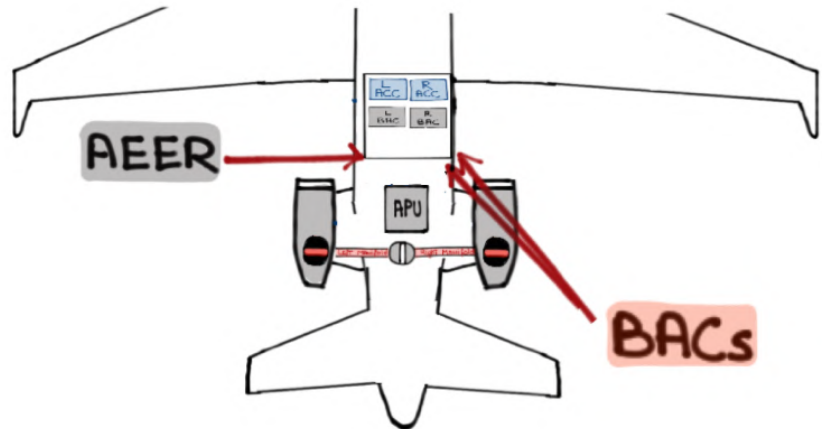
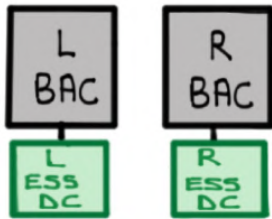

- ISOLATION VALVE

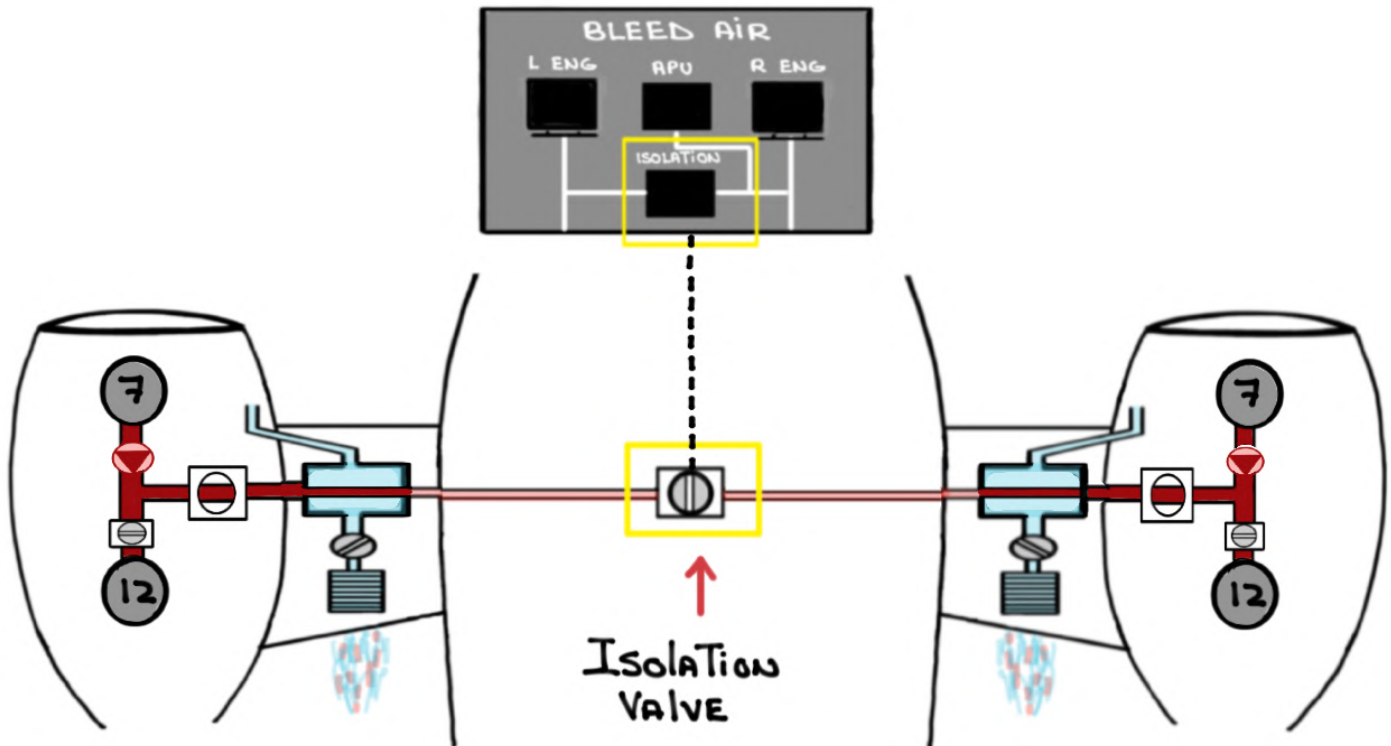

- PRESSURE REGULATING/SHUTOFF VALVES (PRSOV)

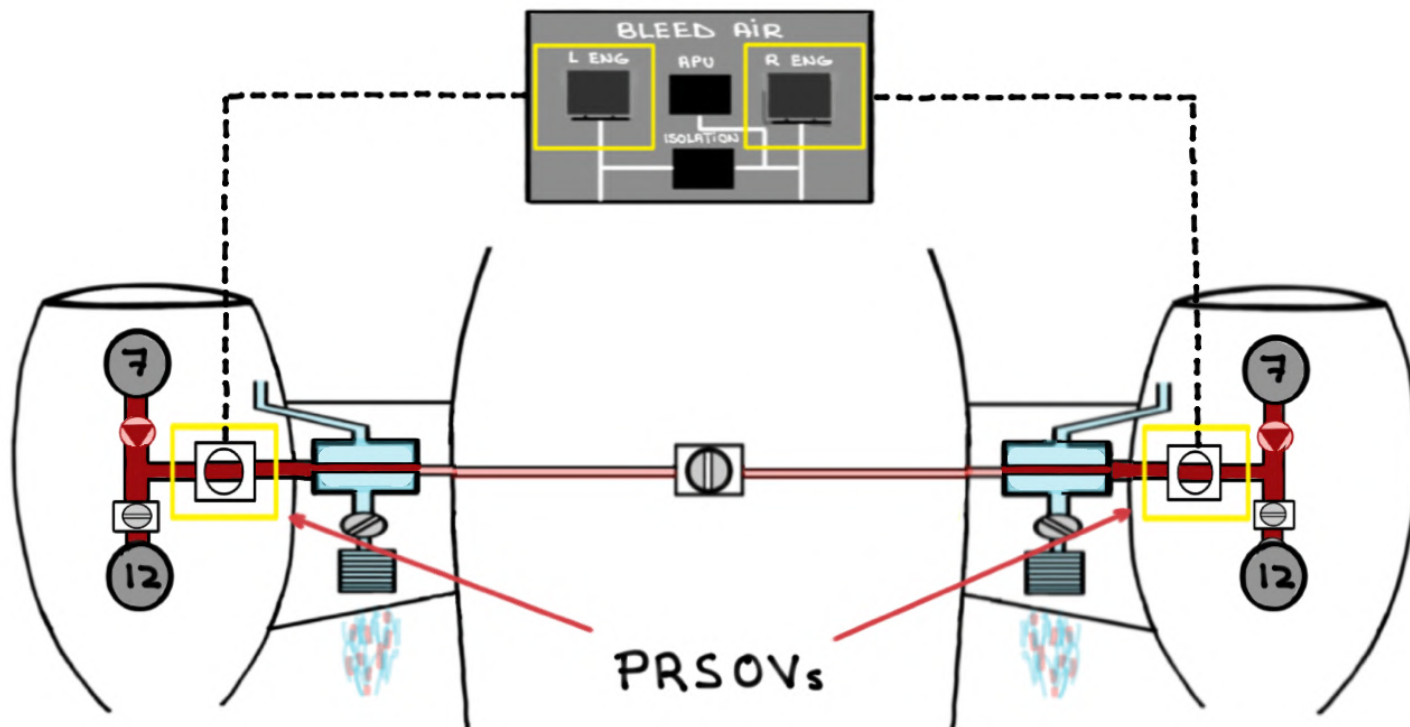

- High-PRESSURE SHUTOFF VALVES (HPSOV)

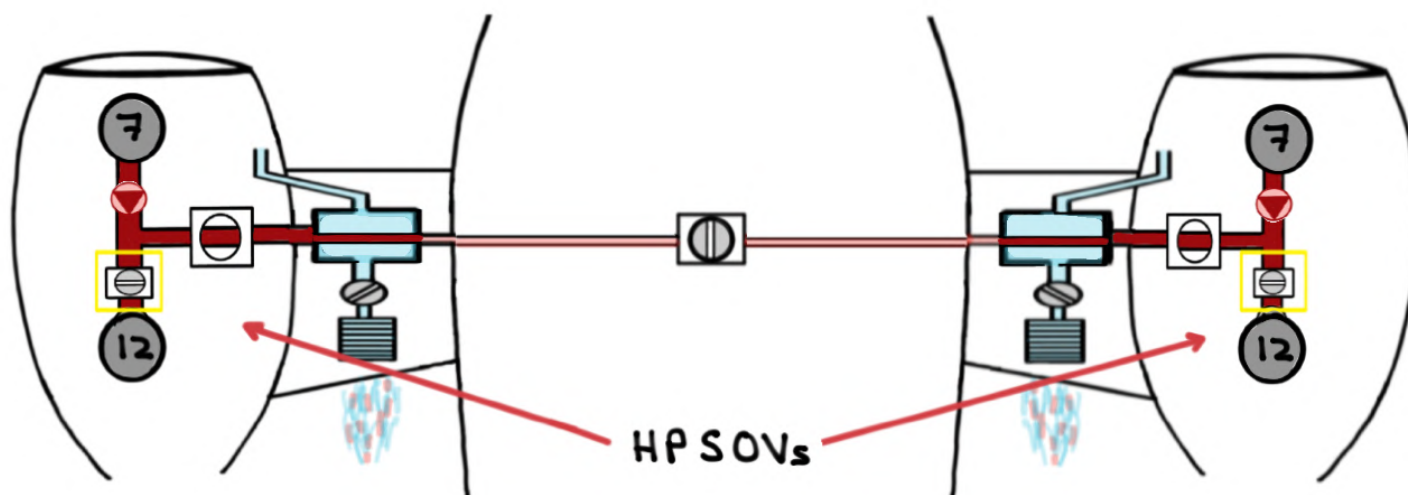

- FAN Air Valves

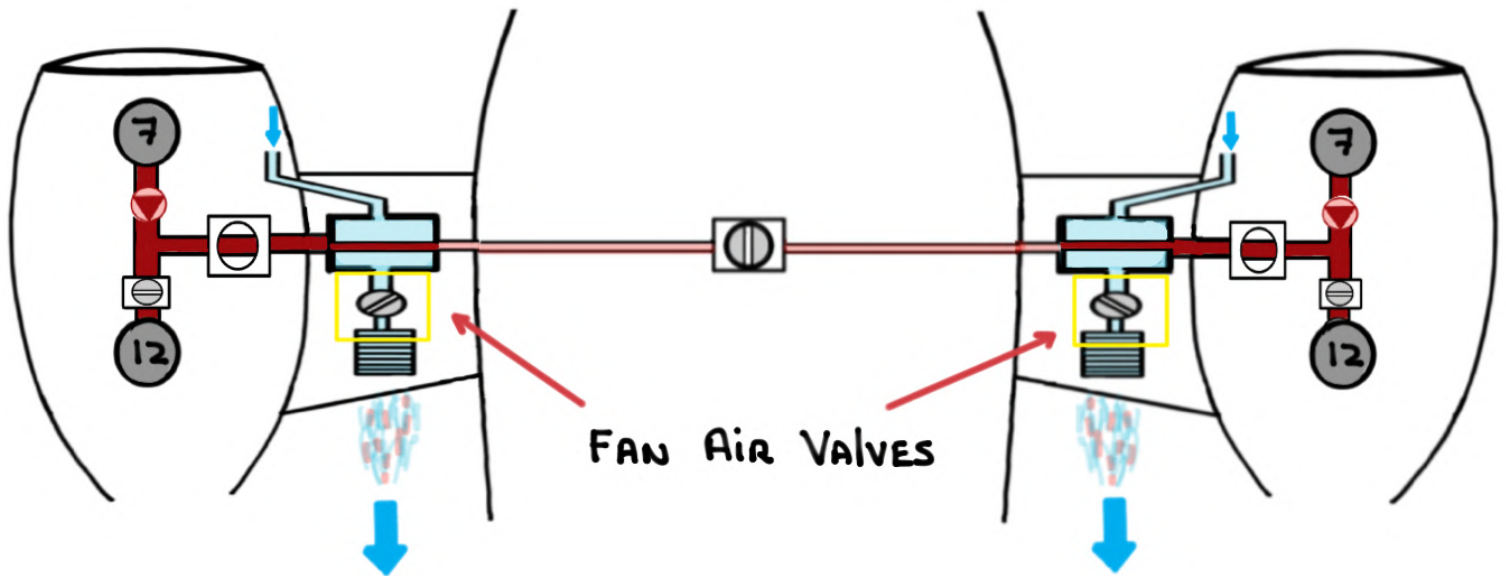

- PRESSURE/TEMPERATURE SENSORS

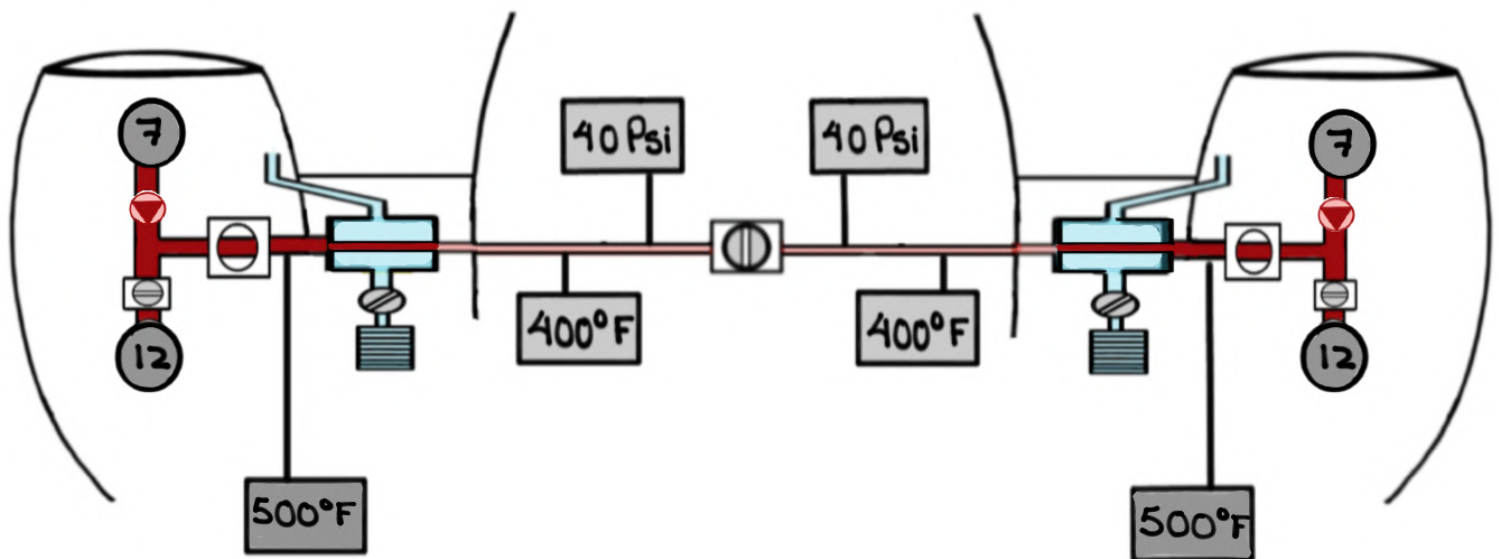

- CHECK VALVES (ONE-WAY flow)

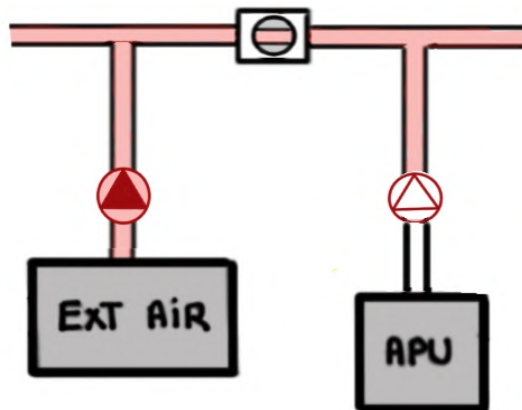

- High-PRESSURE STAGE 7 (HP7) Air NON-RETURN VALVES

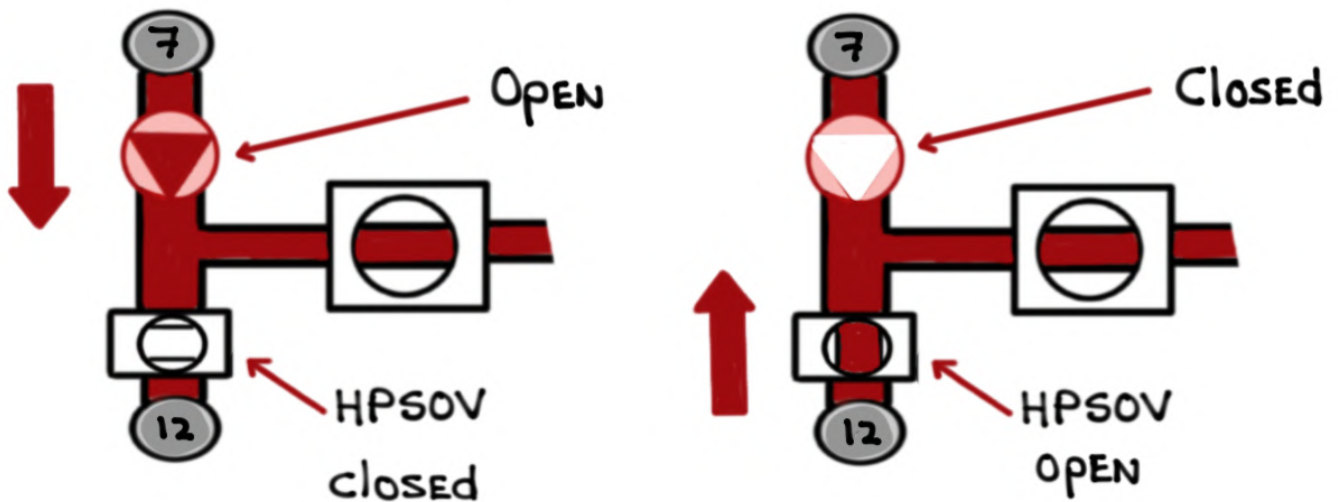

HPSOV, if OPEN, allows higher pressure from the 12TH STAGE PORT TO close the 7TH STAGE check VALVE

BLEED AIR CONTROLLERS (BACs)

THE PNEUMATIC SYSTEM IS REGULATED BY TWO (2) IDENTICAL AND INTERCHANGEABLE MICROPROCESSORS

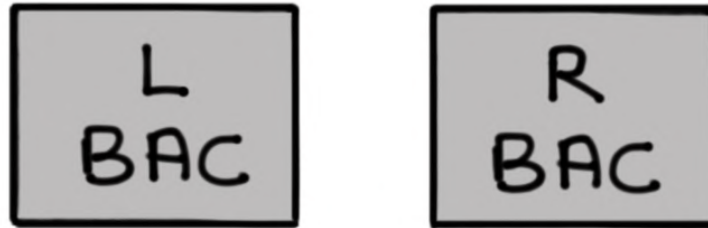

- THE BACs ARE THE BRAINS OF THE SYSTEM
- THE BACs CONTROL MOST PNEUMATIC FUNCTIONS VIA TWO (2) SEPARATE AND INDEPENDENT MANIFOLDS
- PNEUMATIC MANIFOLDS CAN BE CONNECTED BUT ARE NORMALLY OPERATED IN ISOLATION VIA AN ISOLATION VALVE

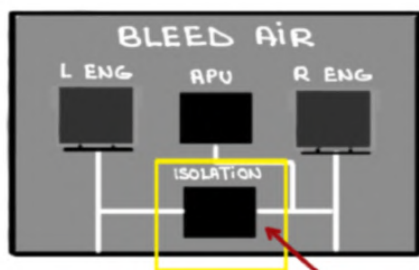

ISOLATION VALVE
CLOSED

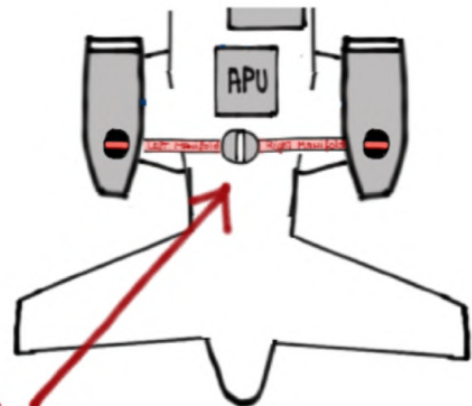

- This design prevents total loss of pneumatic air in the event of a leak in one of the manifolds

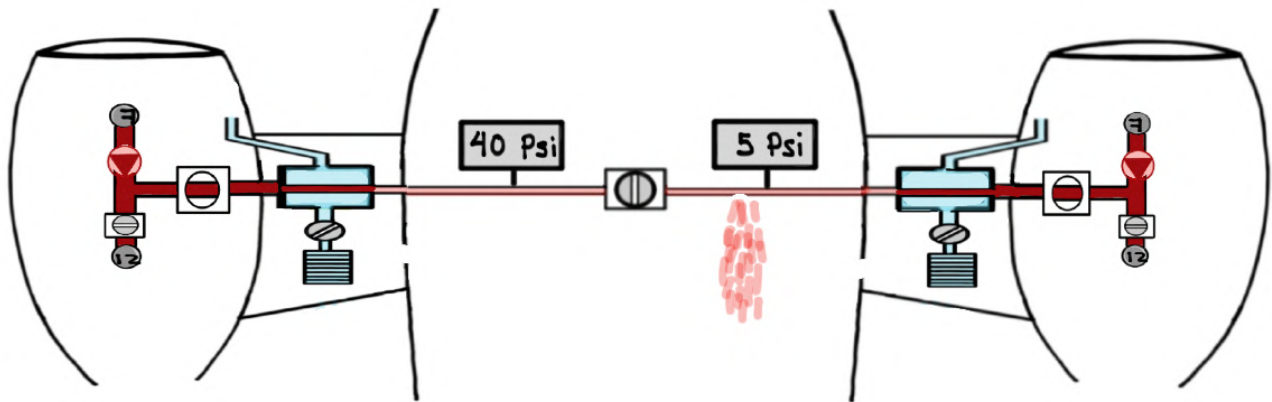

- The BACs ARE located in the AEER

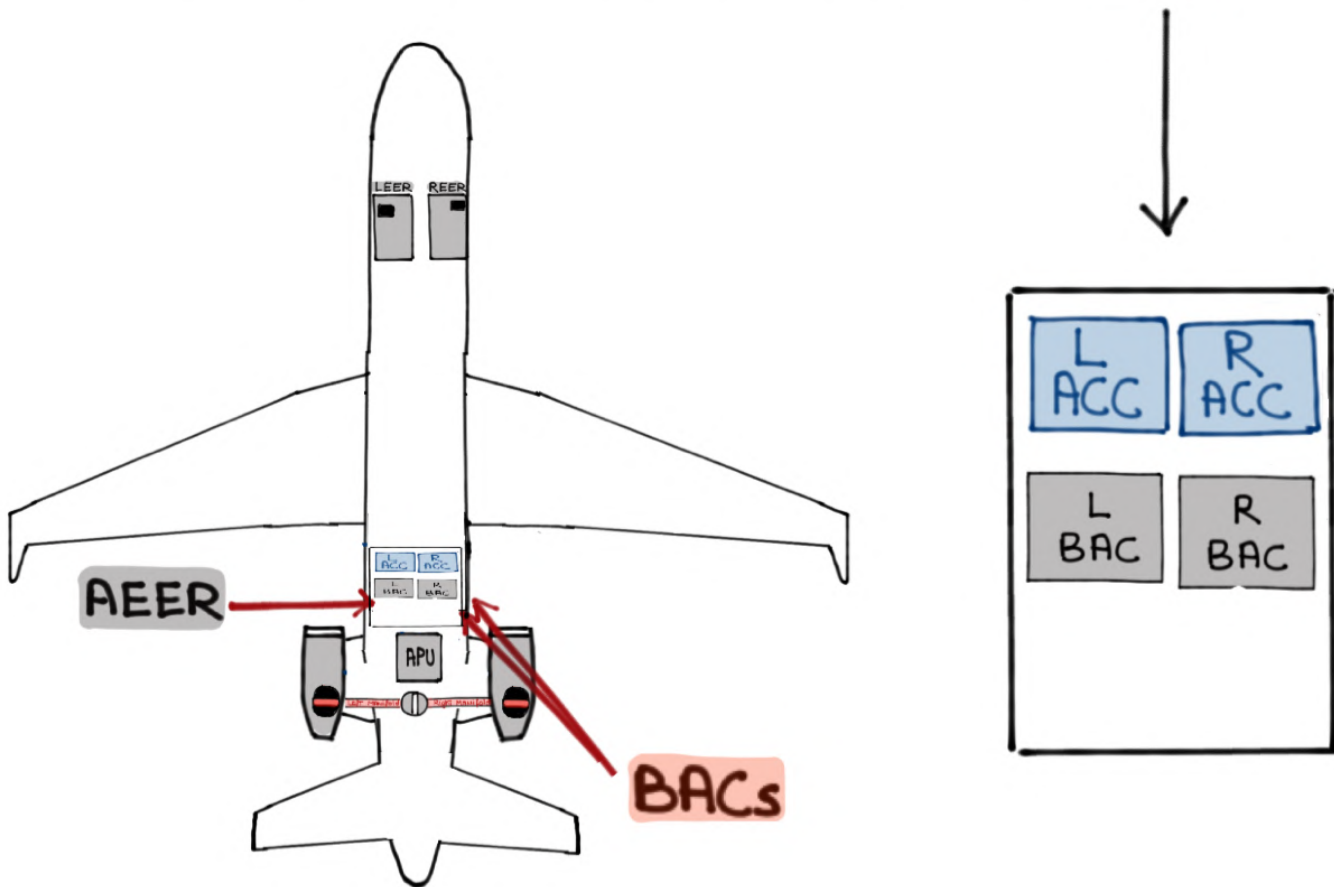

- The **L BAC** **R BAC** RECEIVE DATA AND Cockpit input FROM THE following SOURCES:

DATA input:

- AIRCRAFT ALTITUDE
- STATIC AIR TEMPERATURE (SAT)
- ENGINE LP RPM
- PRECOOLER INLET TEMPERATURE
- PRECOOLER OUTLET TEMPERATURE
- BLEED MANIFOLD PRESSURE
- WING ANTI-ICE TEMPERATURE

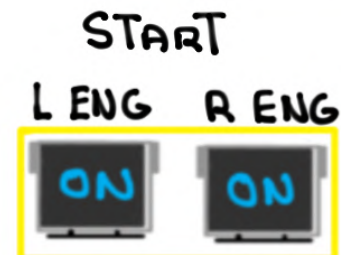
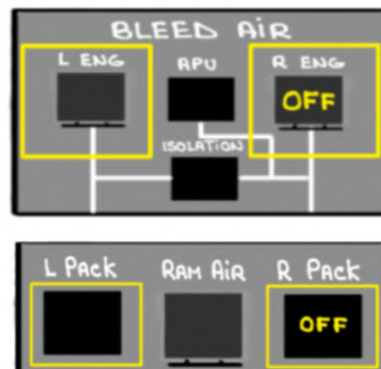
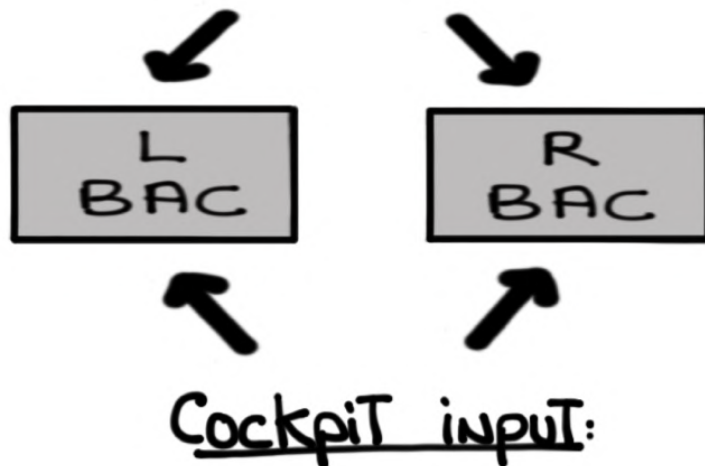

- The L
BAC R
BAC PROCESS DATA AND Cockpit input
AND BASED ON SYSTEM REQUIREMENTS COMMAND
THE following valves TO MODULATE AS REQUIRED:

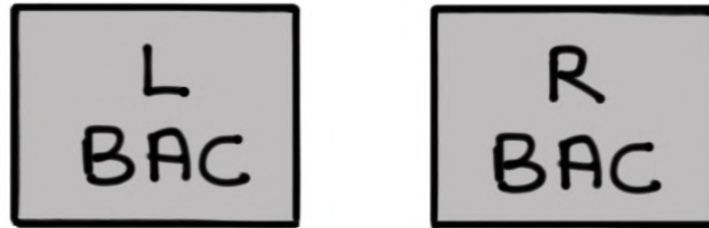

High-PRESSURE ShutOff Valves (HPSOV)
FAN Air Valves

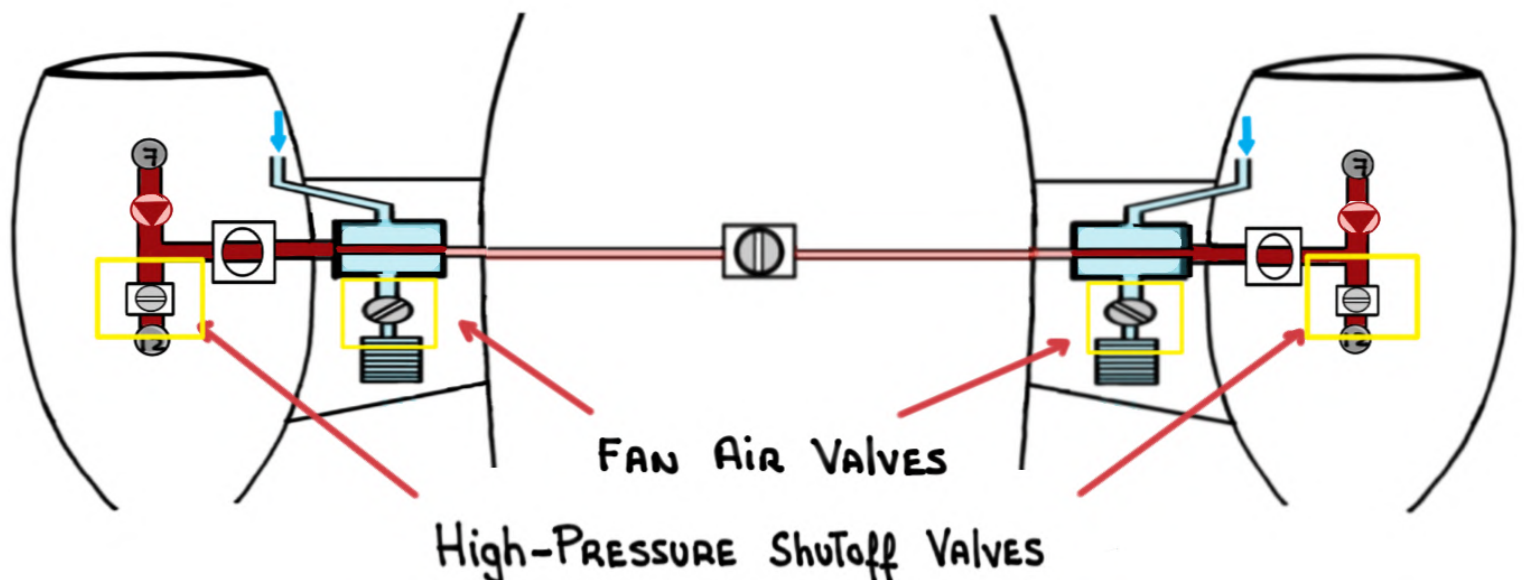

- The L
BAC R
BAC MODULATE THESE VALVES IN ORDER
TO PRODUCE PROPER AIR BASED ON SPECIFIC SYSTEM
REQUIREMENTS

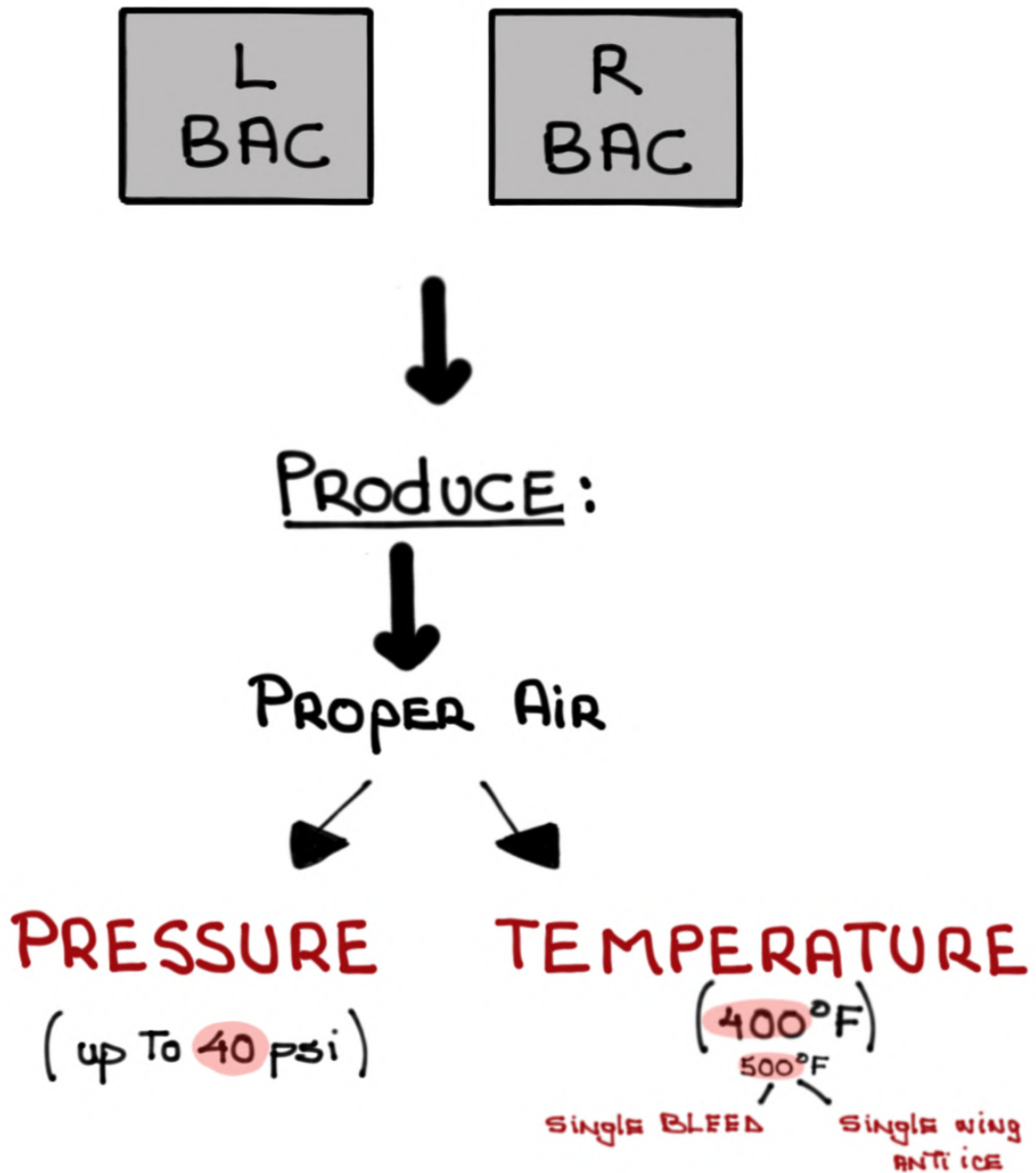

MAIN ENGINES BLEED AIR

- ① Mid-stage bleed (7TH STAGE of HP compressor).
If insufficient, in TERMS of **PRESSURE** AND **TEMPERATURE**, will use High-stage bleed air

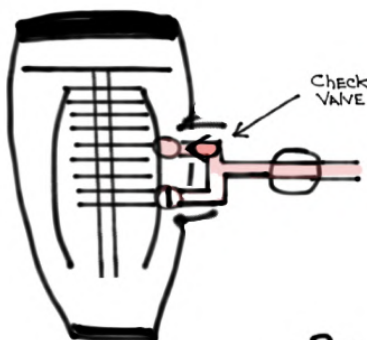
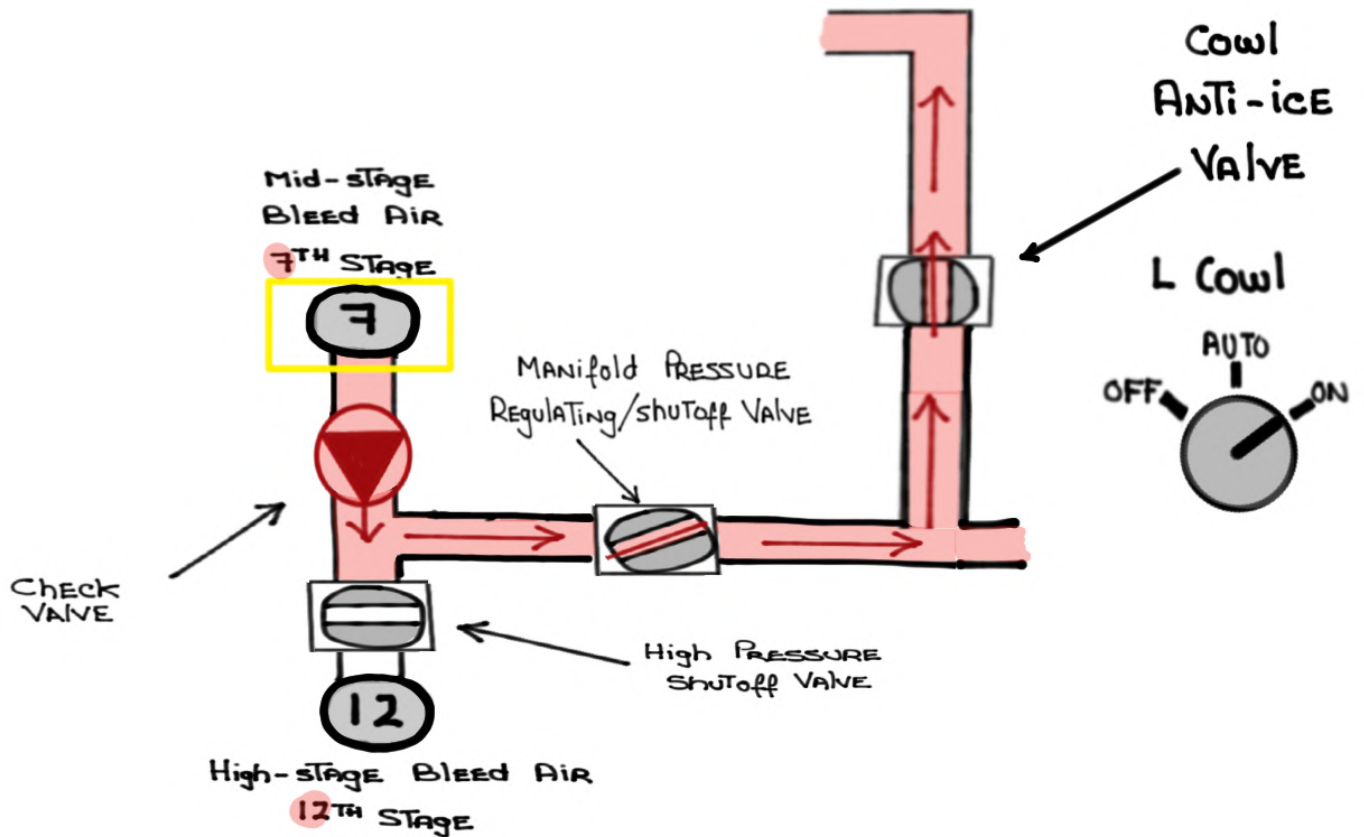

- 7TH STAGE PORT
- 7TH STAGE check valve

PREVENTS higher PRESSURE 12TH STAGE bleed from ENTERING THE 7TH STAGE PORT

② High-stage bleed (12TH STAGE OF HP COMPRESSOR)

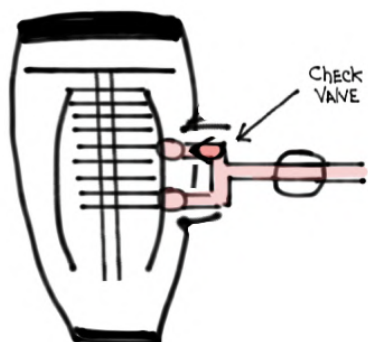
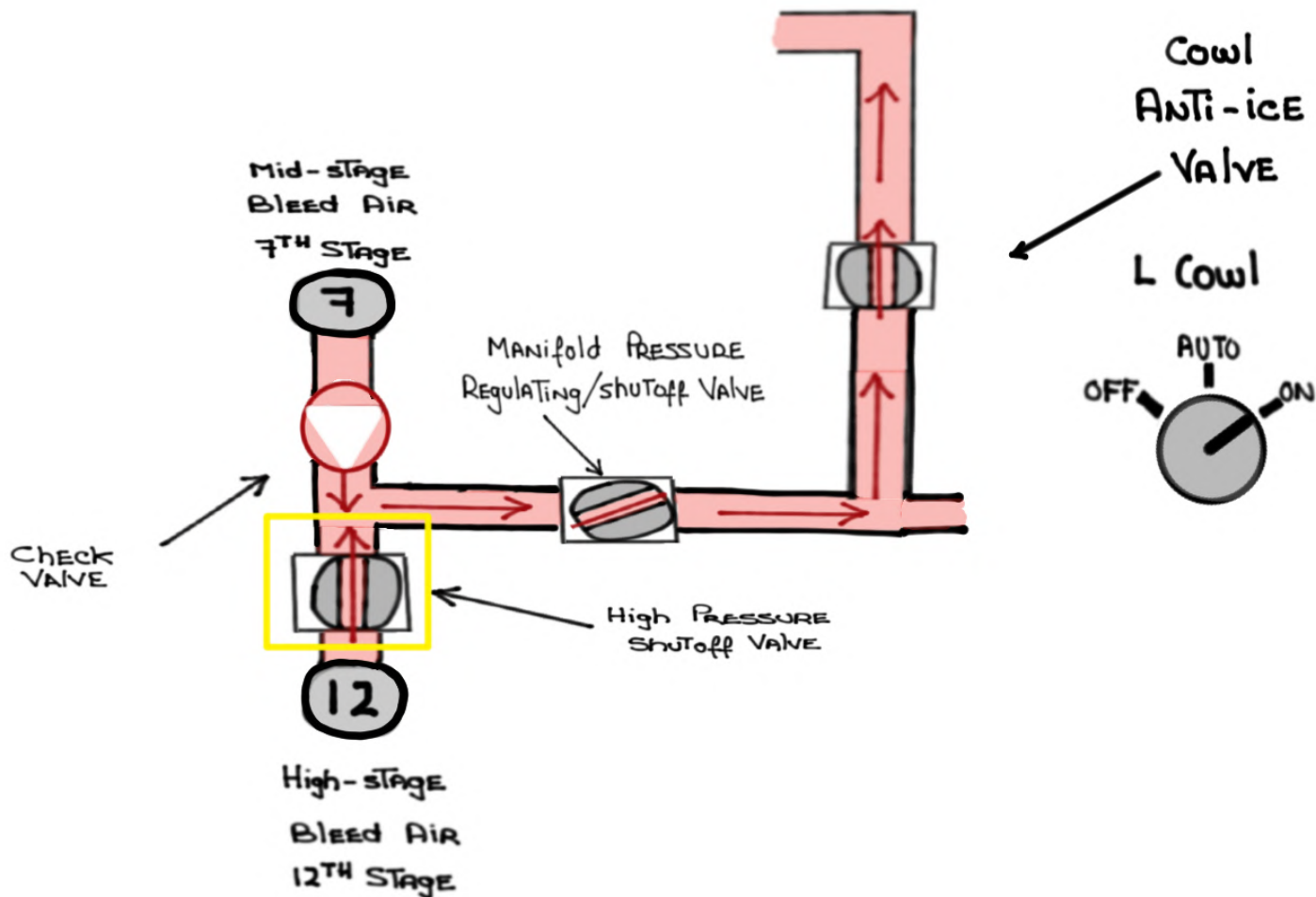

- 12TH STAGE PORT
- 12TH STAGE VALVE

APU BLEED AIR

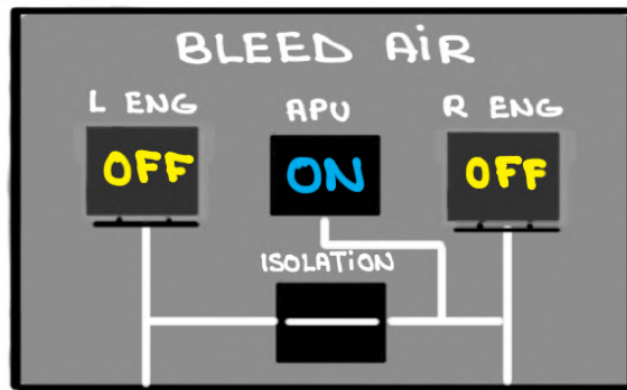

The APU's Load Control Valve (LCV) allows High PRESSURE/TEMPERATURE AIR INTO THE LEFT AND Right PNEUMATIC MANIFOLDS

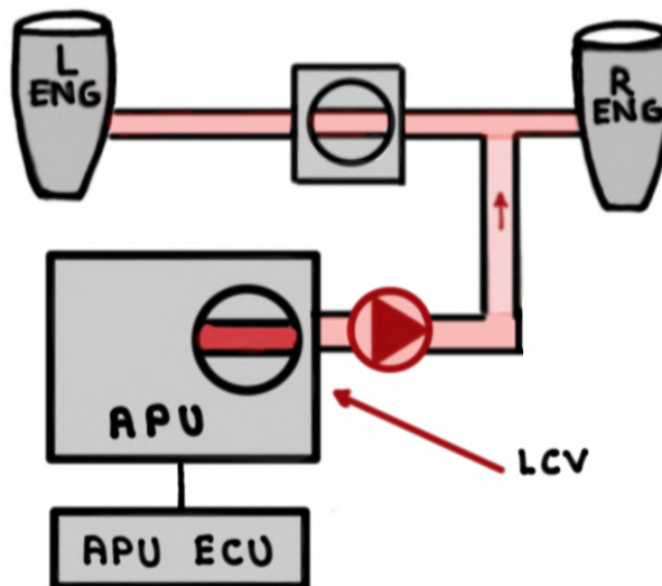

APU bleed air plumbing CONNECTS DIRECTLY TO THE R MANIFOLD

- A flapper-type check valve opens when APU or EXTERNAL AIR PRESSURE IS GREATER THAN MANIFOLD PRESSURE. This allows THE APU OR EXTERNAL AIR TO PRESSURIZE THE PNEUMATIC MANIFOLD

THE CHECK VALVE PROTECTS THE APU AGAINST REVERSE FLOW ORIGINATING FROM THE ENGINES

- SELECTION OF APU BLEED AIR AUTOMATICALLY OPENS THE ISOLATION VALVE TO ALLOW BLEED AIR TO ENTER THE **LEFT** MANIFOLD

- WOW-**G**
- APU STABILIZED AT **100%** RPM
- NINETY (90) SECOND DELAY IF EGT < **149°C**

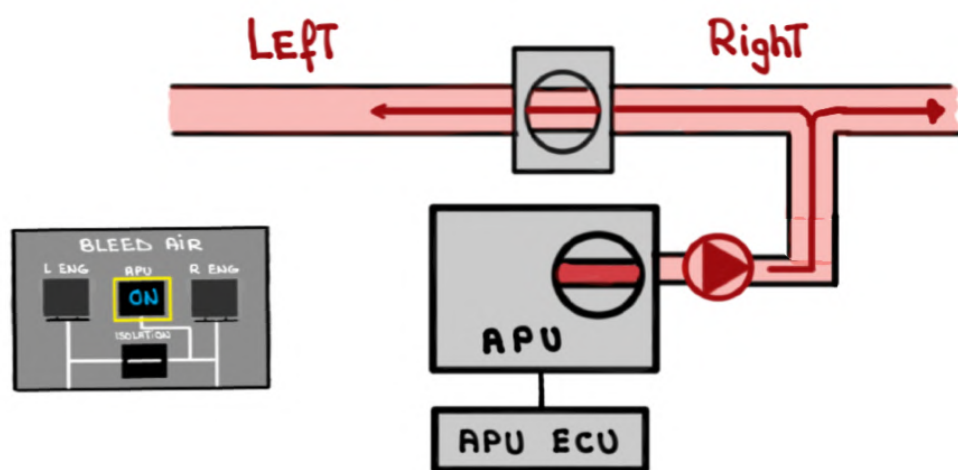

- If THE EGT IS WARM (> **149°C**) THE NINETY (90) SECOND TIME DELAY IS REMOVED AND APU PNEUMATIC AIR WILL BE AVAILABLE IMMEDIATELY

EXTERNAL AIR

- PROVIDES AIR FOR MAIN ENGINE START WHEN THE APU IS UNAVAILABLE
- CONNECTS TO THE **LEFT** BLEED AIR MANIFOLD

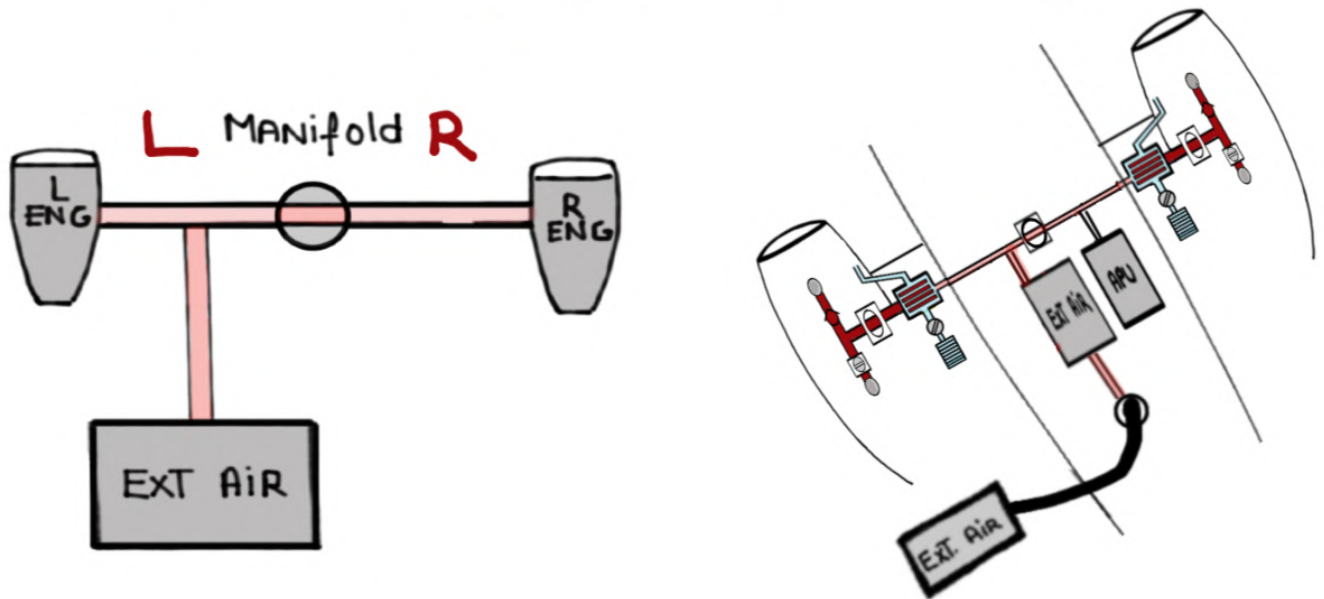

PLACARD ON ACCESS PANEL:

DO NOT CONNECT WITHOUT
ELECTRICAL POWER ON

- DC POWER IS REQUIRED TO OPEN THE ISOLATION VALVE AND THE **L PACK** **R PACK**
- PREVENTS DAMAGE TO THE PACKS DUE TO UNREGULATED AIR

PRESSURE REGULATING/SHUTOFF VALVE (PRSOV)

- LOCATED ON EACH ENGINE
- FUNCTION AS ON/OFF VALVES TO THE PNEUMATIC MANIFOLD
- CONTROLLED by THE LEFT AND RIGHT BLEED AIR SWITCHES

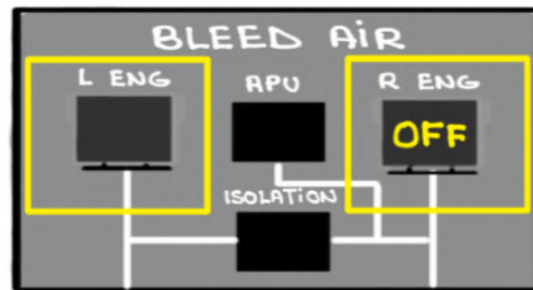

- MODULATE AS NEEDED IN ORDER TO MAINTAIN
up To 40 Psi

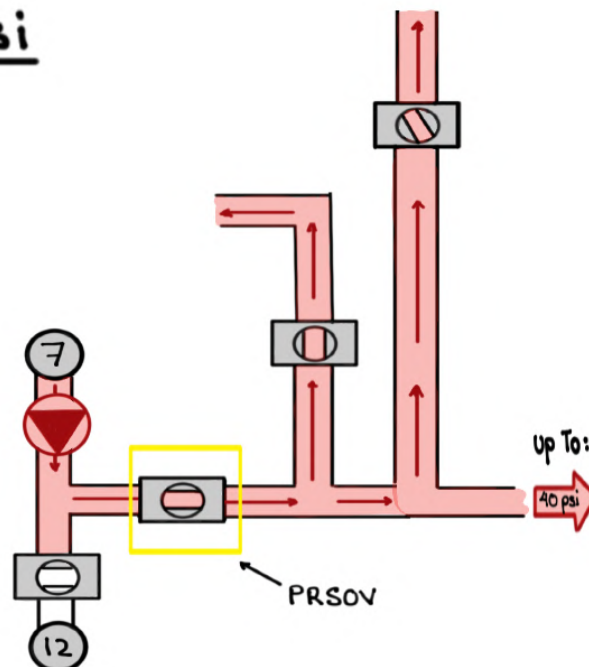

- ELECTRO-PNEUMATIC VALVES. THEY REQUIRE:

- ELECTRICAL POWER TO OPERATE
- PNEUMATIC PRESSURE TO OPEN

- Without   bus POWER will NOT OPERATE

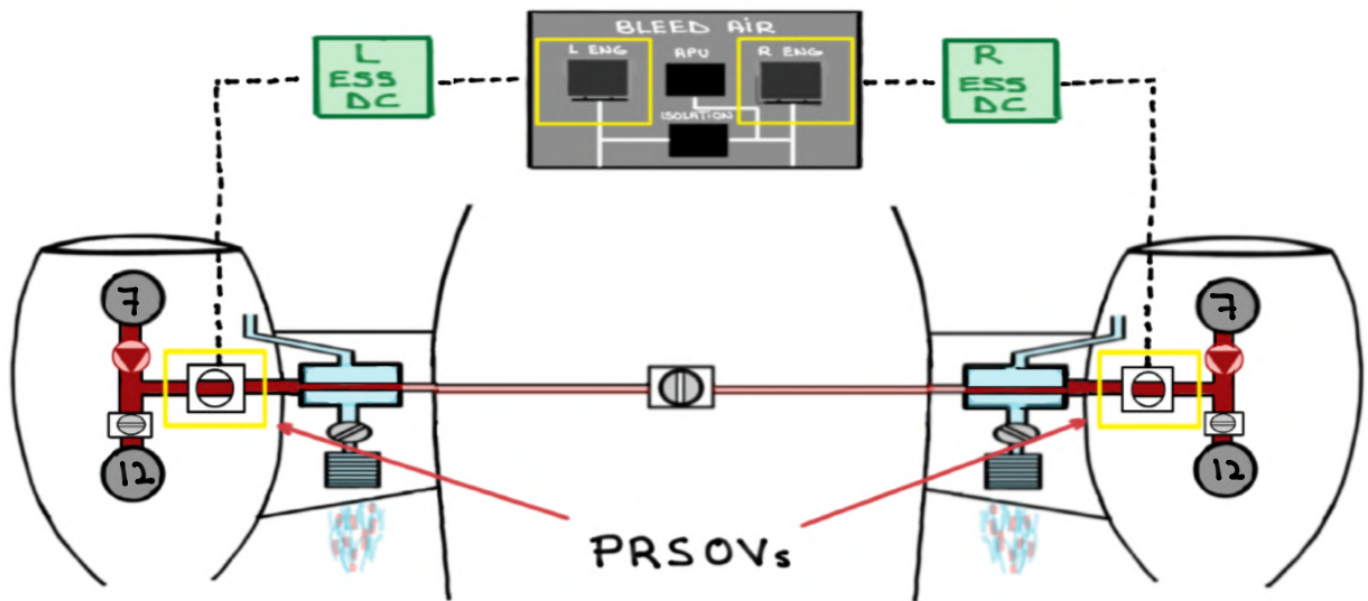

- The bleed air switches MUST be OFF for ENGINE START TO PREVENT A **HOT** START

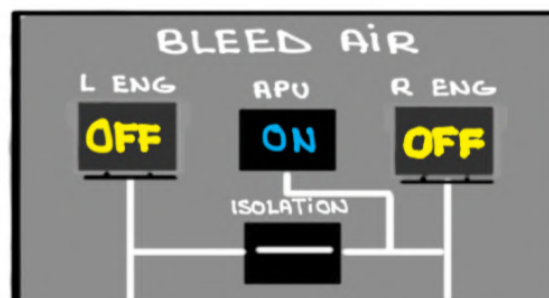

High-STAGE BLEED AIR VALVES

- High PRESSURE ShutOff Valves (HPSOV)
- LOCATED ON EACH ENGINE
- COMMANDED TO MODULATE AS NEEDED BY THE BACs WHEN mid-STAGE bleed air (7TH) is INSUFFICIENT
- Spring-loaded AND fail CLOSED

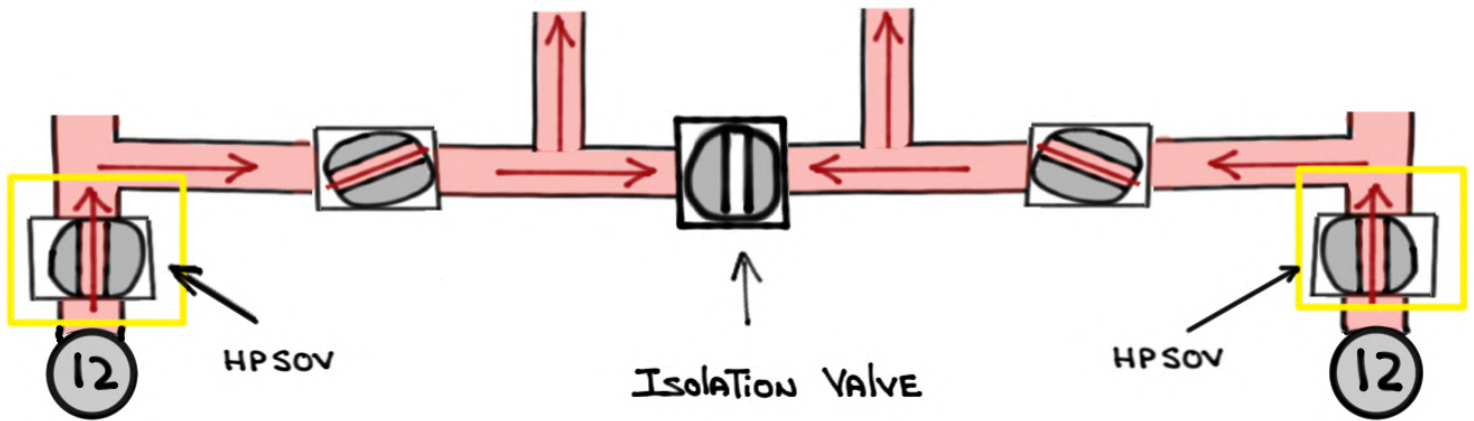
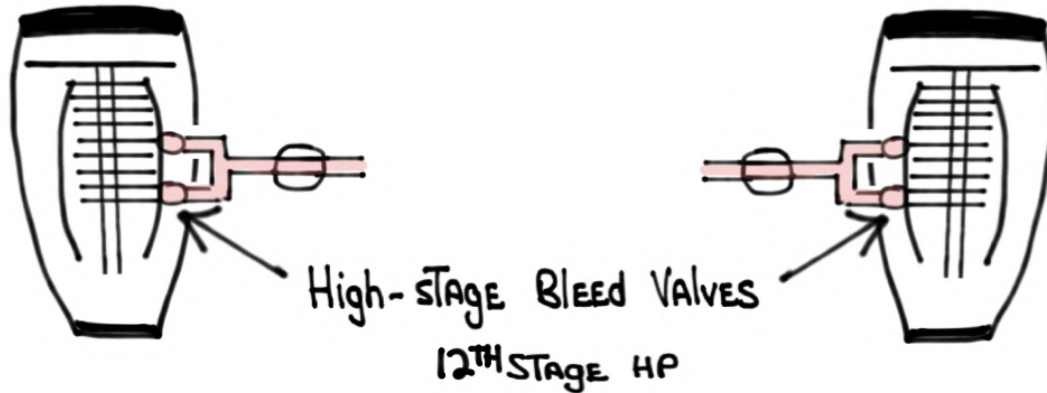
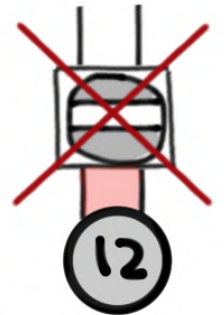

ISOLATION VALVE

- LOCATED IN THE TAIL COMPARTMENT

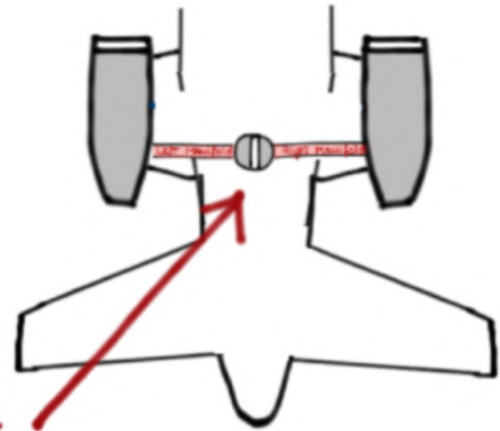
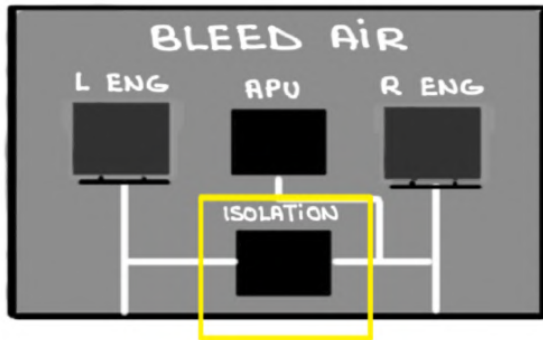

ISOLATION VALVE
CLOSED

- POWERED by L
ESS
DC bus
- Without L
ESS
DC bus POWER will NOT OPERATE
- ELECTRO-PNEUMATIC VALVES. THEY REQUIRE:
 - ELECTRICAL POWER TO OPERATE
 - PNEUMATIC PRESSURE TO OPEN
- FAILS FROZEN (i.e., ITS LAST POSITION)

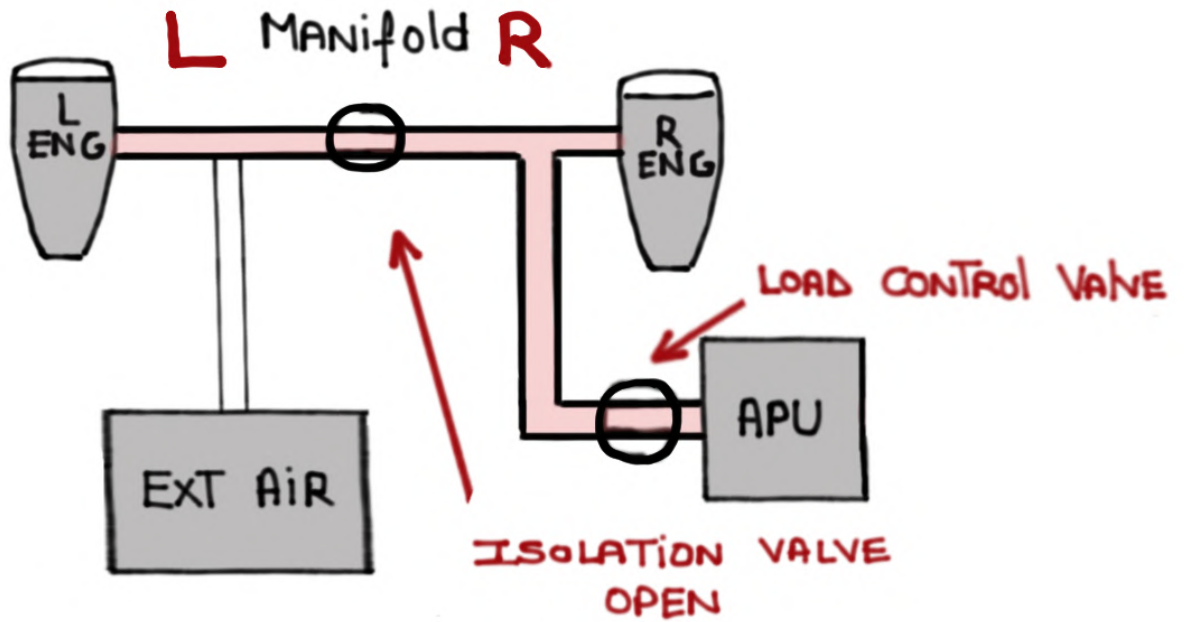

- The Isolation Valve opens:

- ① **START MASTER ON**
 - ② **CRANK MASTER ON**
- BLEED AIR

L ENG	APU	R ENG
OFF	ON	OFF
ISOLATION		
[Switch Icon]		
- ③ APU bleed **ON** (95 % RPM / 90 seconds)
AND WOW - **GROUND**
 - ④ Isolation switchlight MANUALLY SELECTED OPEN

PRECOOLER HEAT EXCHANGER

- ENGINE BLEED AIR IS EXTREMELY **HOT** AND WOULD MELT ALUMINUM IF IT IS NOT COOLED
- THE PRECOOLER USES FAN AIR (LP) AND A HEAT EXCHANGER TO COOL ENGINE BLEED AIR DOWN
- THE PRECOOLER HEAT EXCHANGER IS LOCATED IN THE ENGINE PYLON

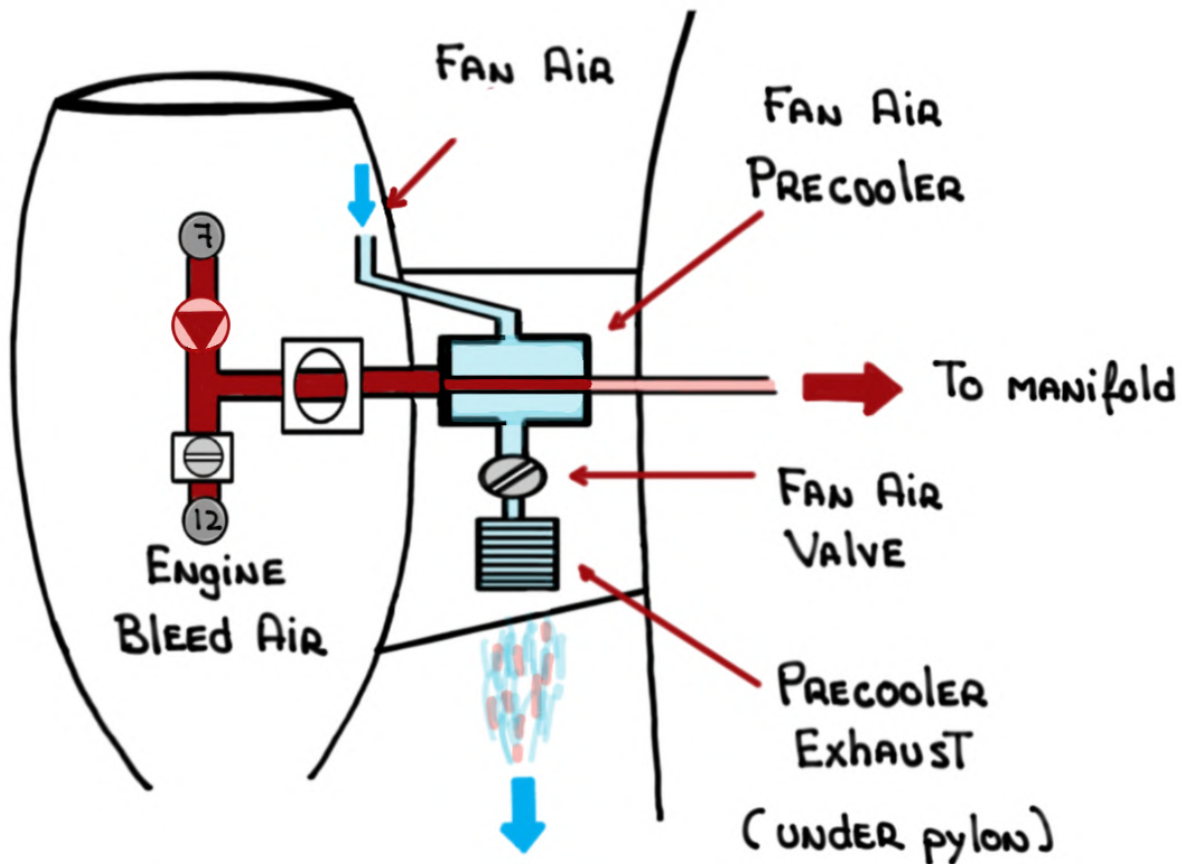

- The **L BAC** **R BAC** monitor PRECOOLER INLET AND OUTLET TEMPERATURE AND MODULATE The opening of The FAN AIR VALVES AS NECESSARY

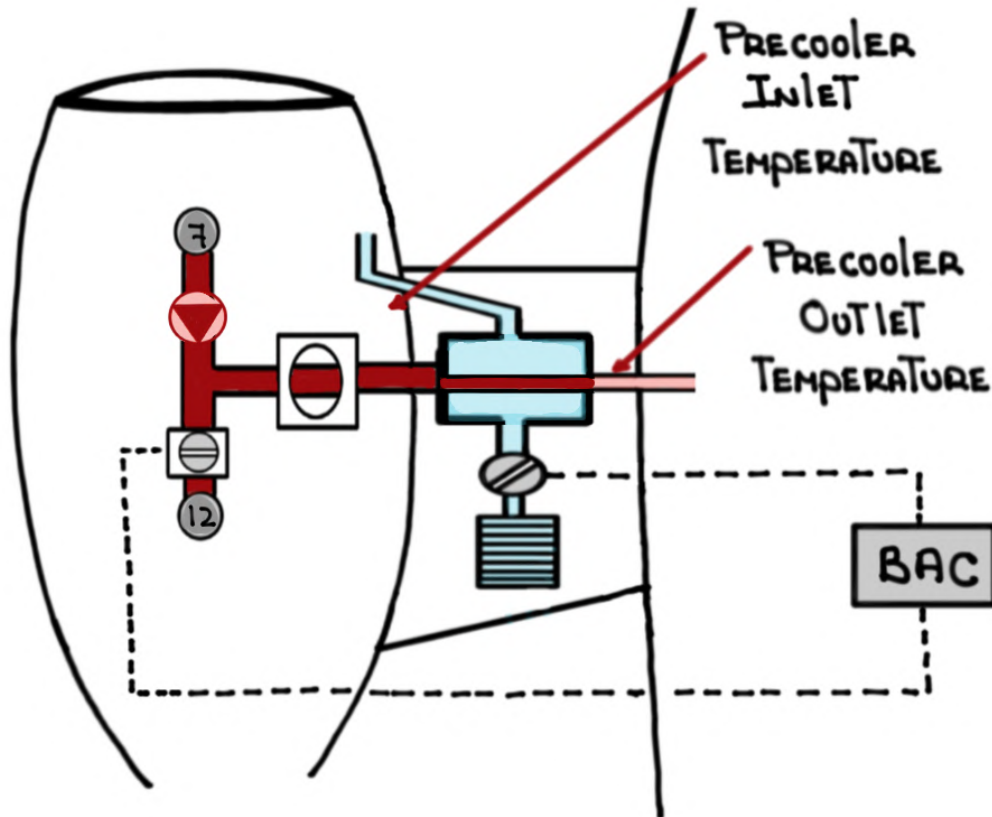

PRECOOLER INLET TEMPERATURE:

WHATEVER mid-STAGE (7TH) OR high-STAGE (12TH) is producing

PRECOOLER OUTLET TEMPERATURE:

- **400°F**

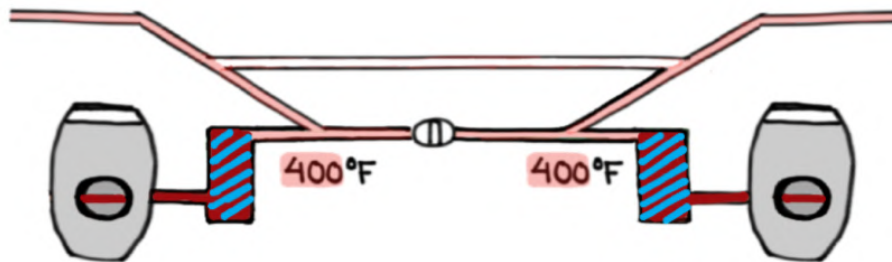

- **500°F** when HOTTER AIR IS NEEDED TO TRAVEL THROUGH CROSSOVER DUCT (LONGER DISTANCE) DUE TO WING ANTI-ICE ON WITH A SINGLE BLEED SOURCE

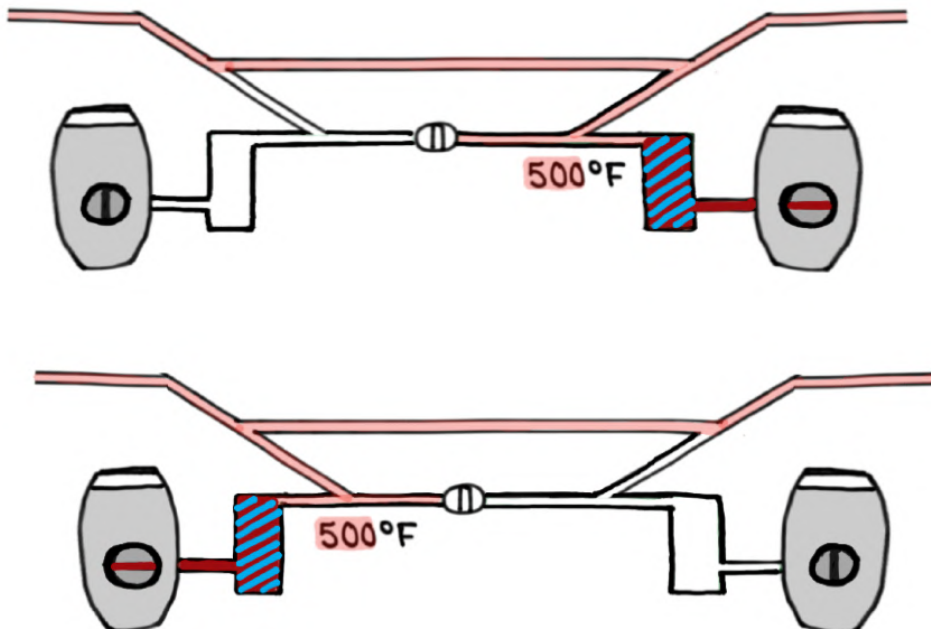

Wing ANTI-ICE SYSTEM

- Wing ANTI-ICE VALVES ARE ELECTRO-PNEUMATIC. THEY REQUIRE:

- ELECTRICAL POWER TO OPERATE
- PNEUMATIC PRESSURE TO CLOSE

- IT USES **HOT** ENGINE BLEED AIR (MID OR HIGH-STAGE)

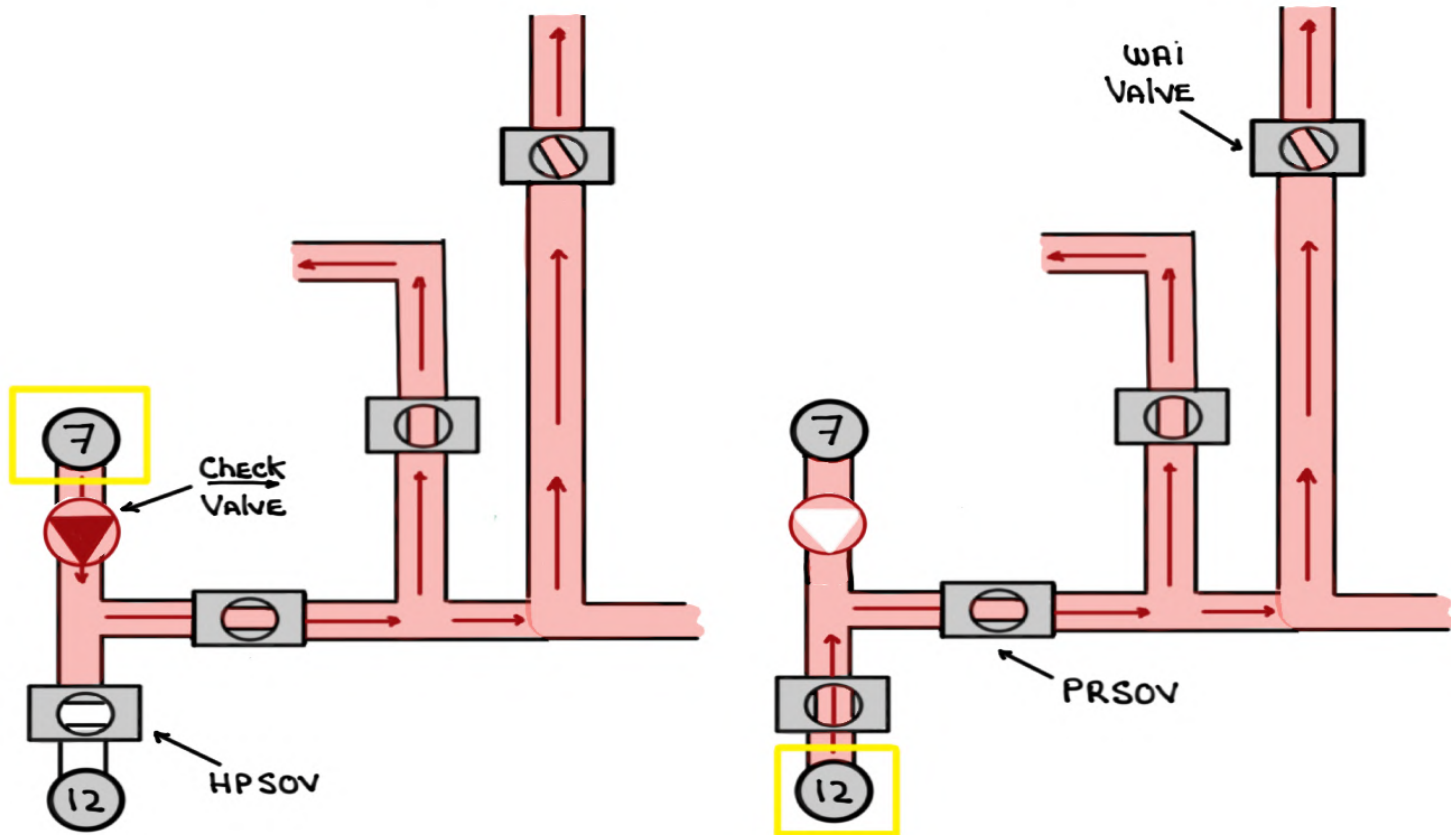

A CHECK VALVE PREVENTS MIXING
BETWEEN 7TH AND 12TH STAGE
BLEED AIR



Cowl ANTI-ICE SYSTEM

- Cowl ANTI-ICE VALVES ARE ELECTRO-PNEUMATIC. THEY REQUIRE:

- ELECTRICAL POWER TO OPERATE
- PNEUMATIC PRESSURE TO CLOSE

- IT USES (7) STAGE BLEED AIR AND CAN BE COMPLEMENTED BY (12) BLEED AIR

L-R Cowl ANTI-ICE ON

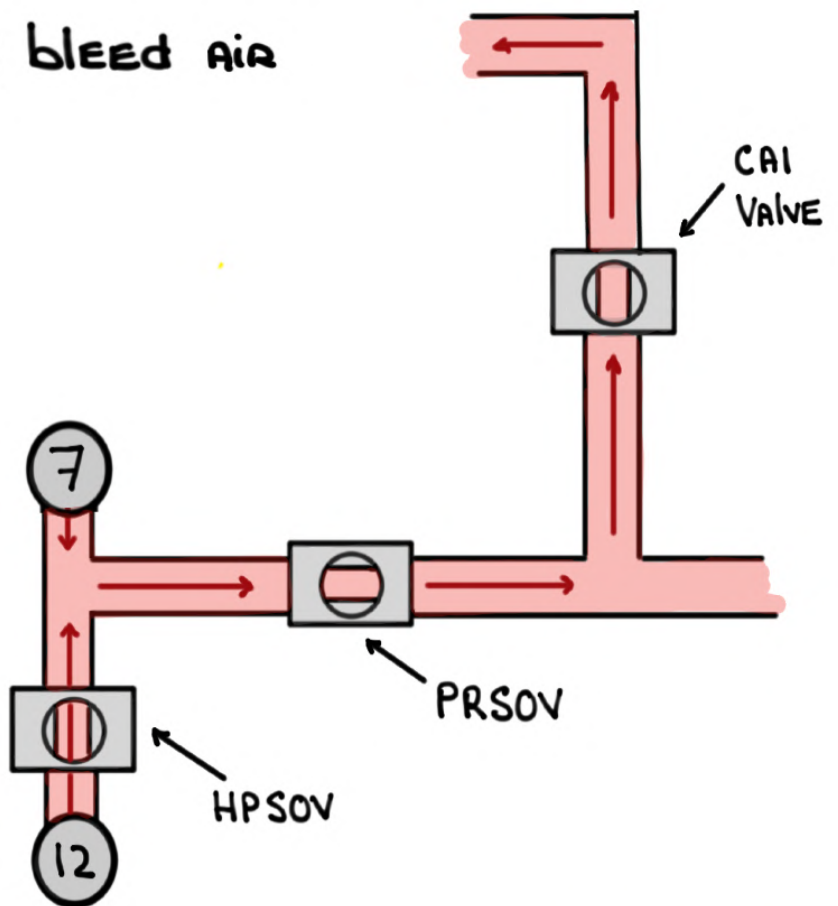
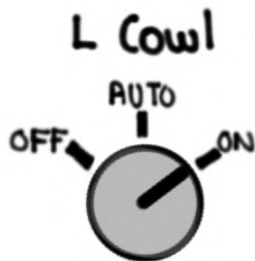

- Cowl ANTI-ICE VALVES FAIL OPEN

L Cowl VALVE FAIL OPEN

SET POINTS

SET POINTS ENSURE ADEQUATE PNEUMATIC PRESSURE AND TEMPERATURE AT THE VARIOUS POWER SETTINGS AND BLEED REQUIREMENTS

- Low power settings = 15-26 Psi
- Single pack = 35 Psi

If mid-stage (7TH) is NOT ENOUGH THE BACS COMMAND THE HIGH-STAGE (12TH) VALVES TO MODULATE OPEN IN ORDER TO PROVIDE UP TO 40 PSI

CONDITION	SOURCE	SET POINT (PSI)
GROUND idle	12 TH	15
FLIGHT idle	12 TH	26
THRUST > idle	7 TH	40 (400°F)
Wing ANTI-ICE (2) idle	12 TH (PRE-COOLER 570°F)	40 (500°F)
Wing ANTI-ICE (2) > idle	7 TH (PRE-COOLER 570°F)	40 (500°F)
Wing ANTI-ICE (1) > idle	7 TH (PRE-COOLER 570°F)	40 (500°F)
SINGLE PACK	12 TH	35 (500°F) * inop pack off

BLEED AIR PRESSURE SENSORS

> 75 Psi **L BLEED PRESSURE High**

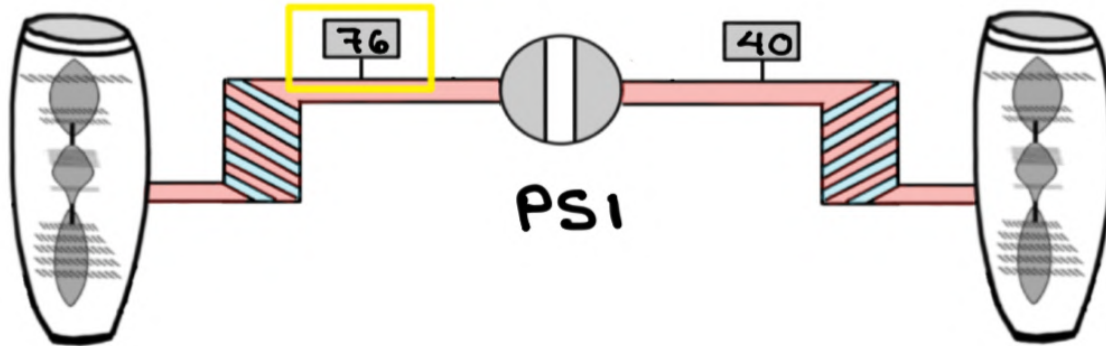

< 5 Psi > 10 seconds **R BLEED PRESSURE LOW**

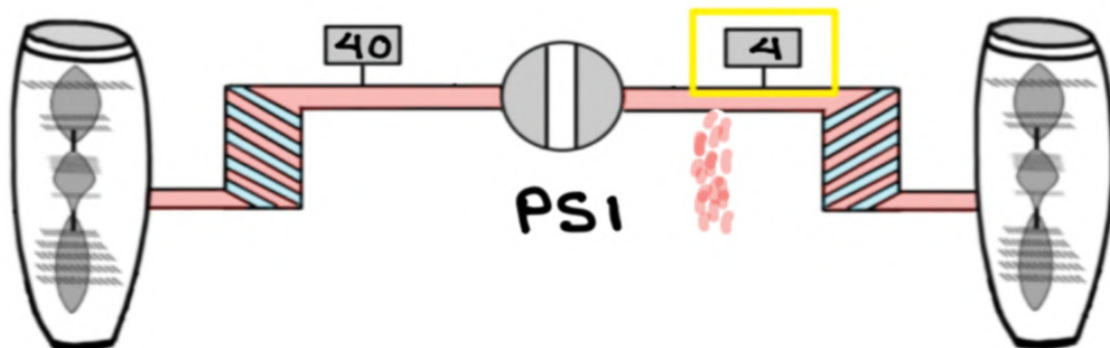

BLEED AIR TEMPERATURE SENSORS

L BLEED AIR HOT > 735 °F INLET

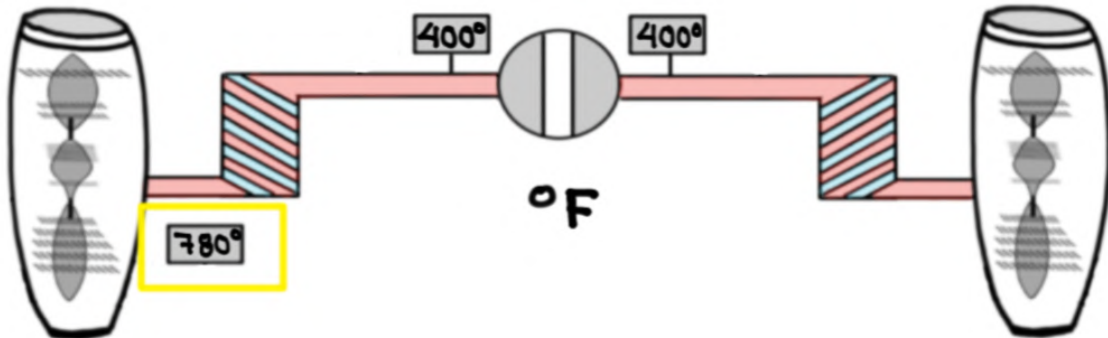

R BLEED AIR HOT > 550 °F OUTLET

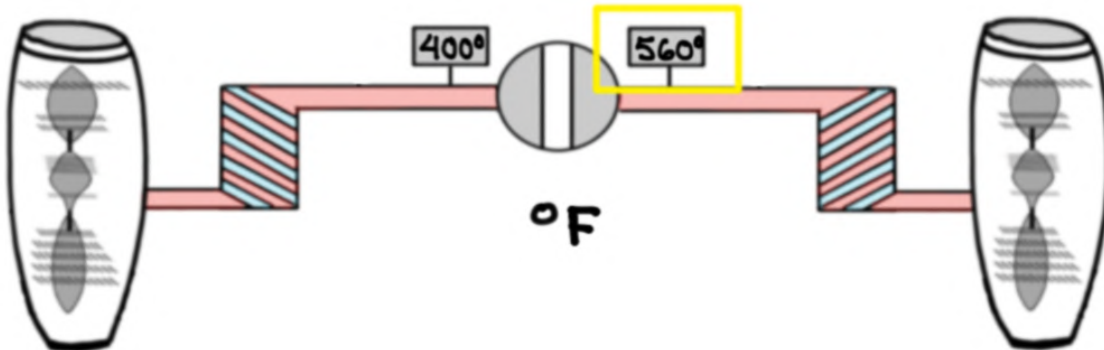

REMINDER: these system notes are intended for study purposes only. Always refer to official Gulfstream manuals and other approved references when operating your aircraft.

NOTE: these system notes are updated from time to time and what is posted on Code450.com will always be the most recent version.

Questions, comments or errors...please do send me an email:
ivan@code7700.com



Thank you!