

G600 FUEL SYSTEM

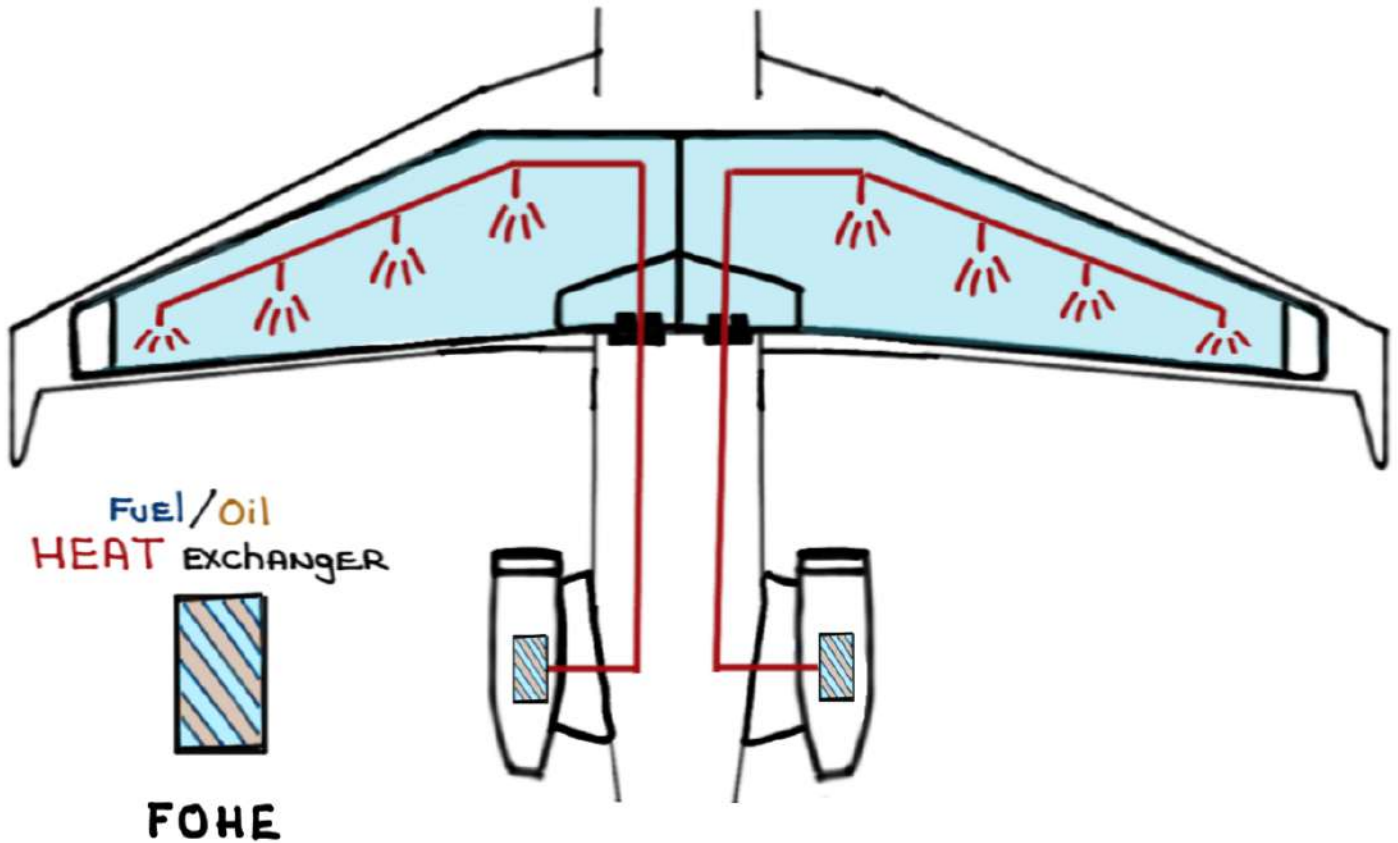

For study purposes only

The FUEL SYSTEM consists of two (2) wing TANKS which STORE all fuel and FEED the MAIN ENGINES AND APU via low pressure, electrically-driven boost pumps

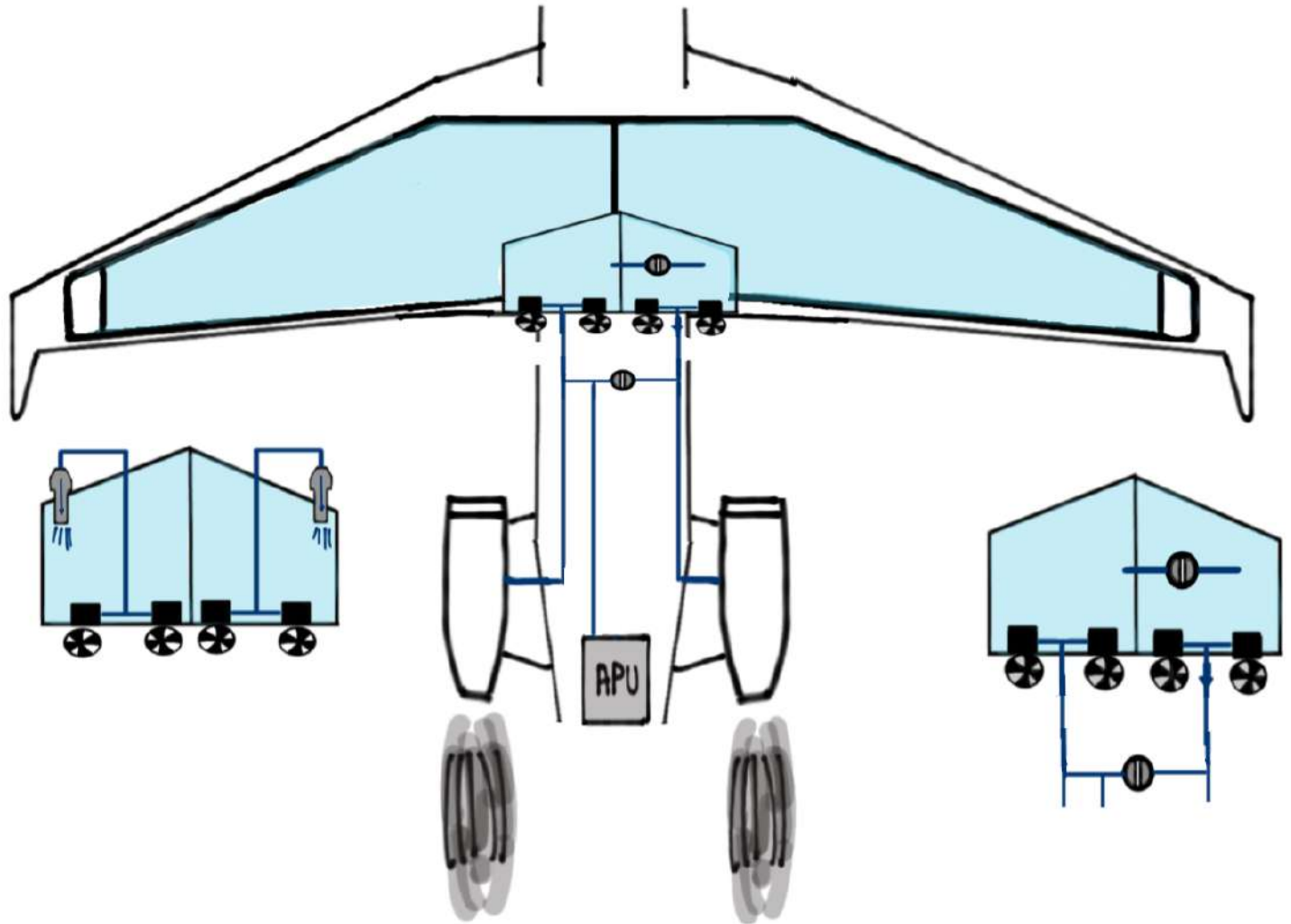

- The wing TANKS ARE PART OF THE INTERNAL wing STRUCTURE AND DO NOT HAVE bladders

Wing TANKS

- PRESSURE REFUELING CAPACITY:

- RIGHT TANK: 20,750 lbs
- LEFT TANK: 20,750 lbs

- TOTAL: 41,500 lbs

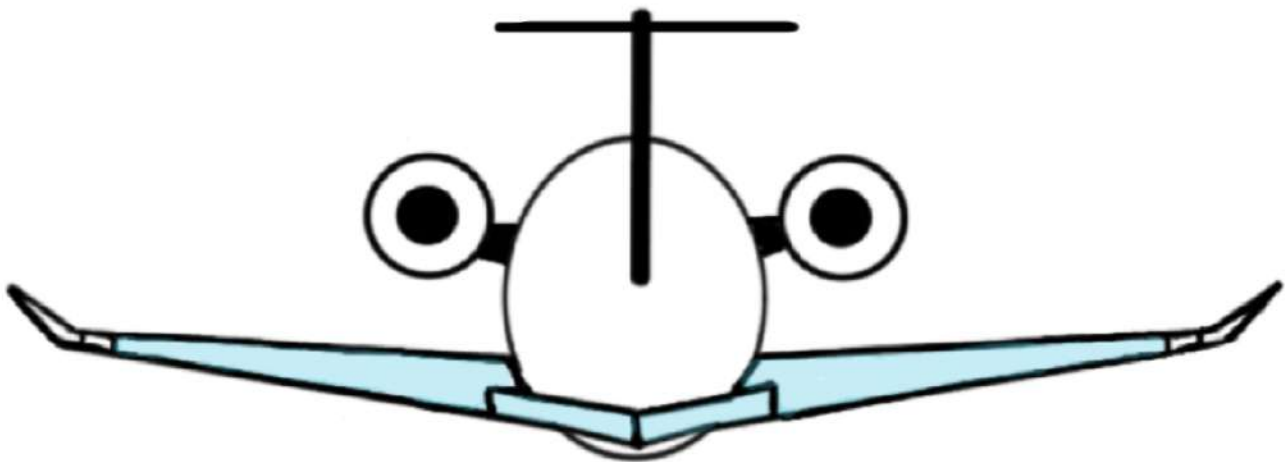

If EITHER FUEL TANK QUANTITY EXCEEDS 20,750 lbs
THE FUEL QUANTITY DIGITAL READOUT ON THE ENGINE
INSTRUMENTS AND SYNOPTICS DISPLAYED ON THE DUs
WILL HAVE WHITE DASHES ON THE AFFECTED SIDE(S)
AND THE TOTAL FUEL QUANTITIES

- Refueling:

① Single-point pressure refueling (35-55 PSI)

② Overwing gravity refueling - MAXIMUM capacity:

33,500 lbs

- Rapid changes in C.G. due to slushing are avoided through the use of baffle ribs within the tanks. This design creates multiple compartments or bays within the wing tanks

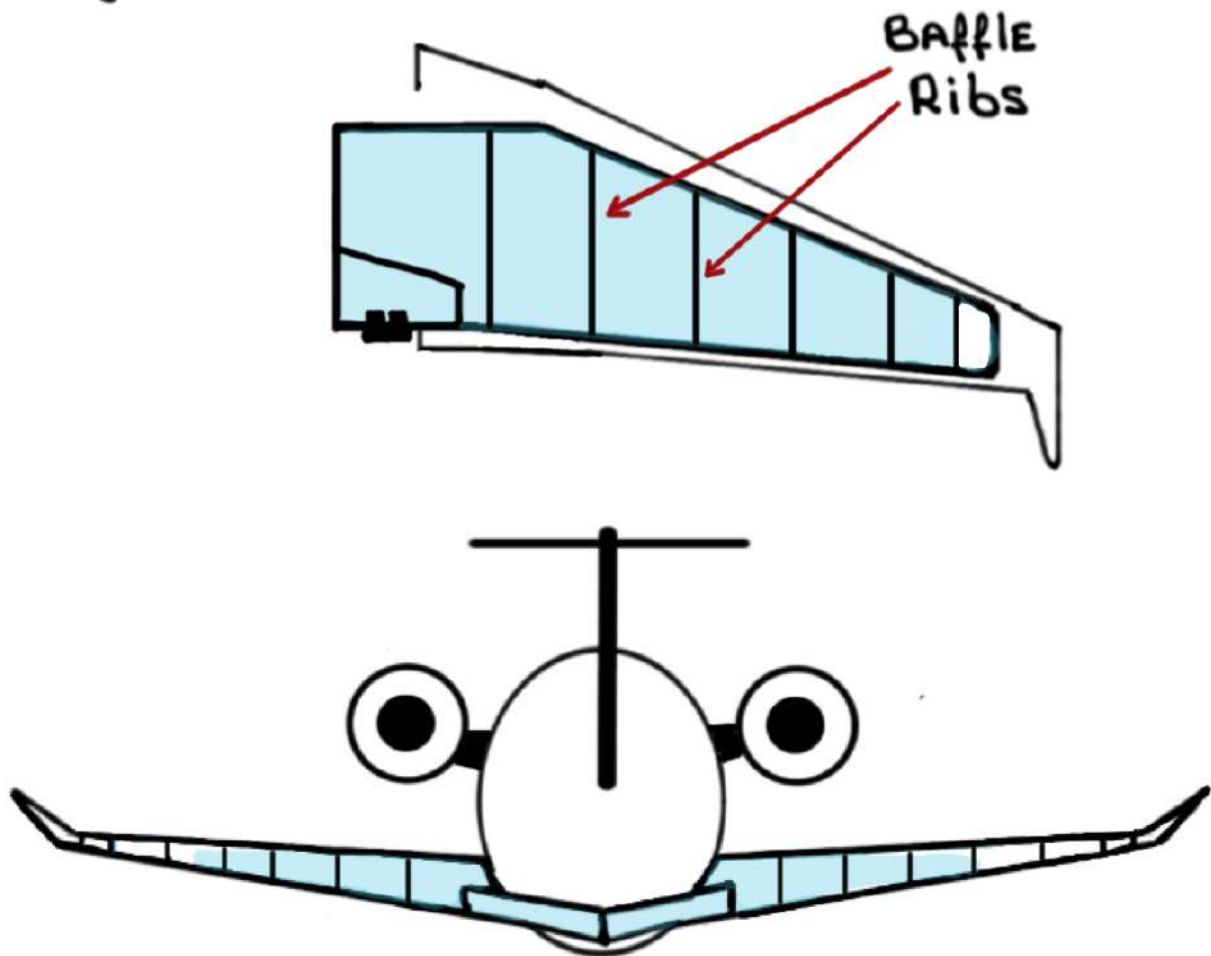

- FLAPPER VALVES AT THE BOTTOM OF EACH BAFFLE RIB ALLOW FUEL TO TRAVEL IN ONE DIRECTION FROM COMPARTMENT TO COMPARTMENT AND TOWARDS THE FUEL HOPPERS

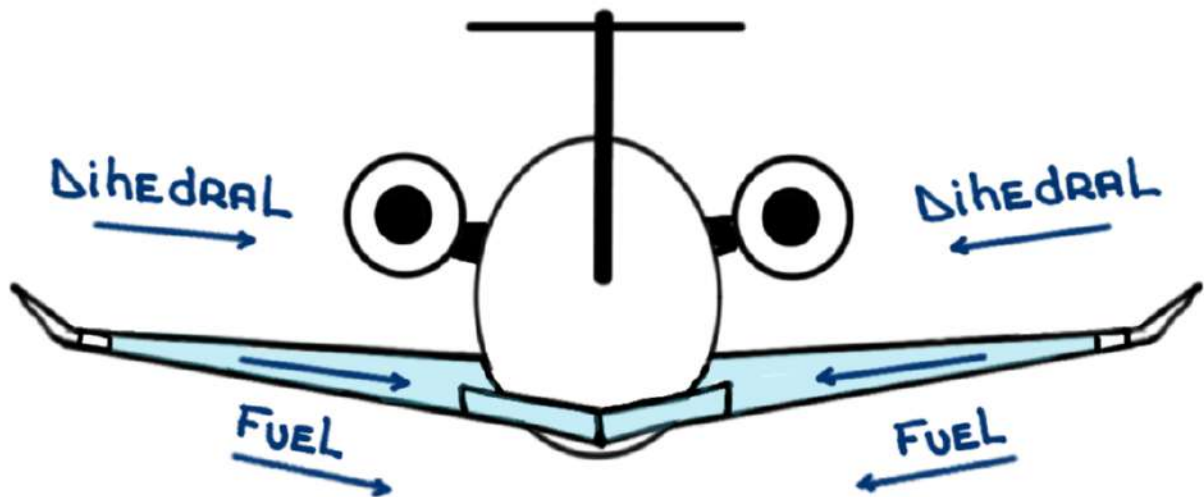
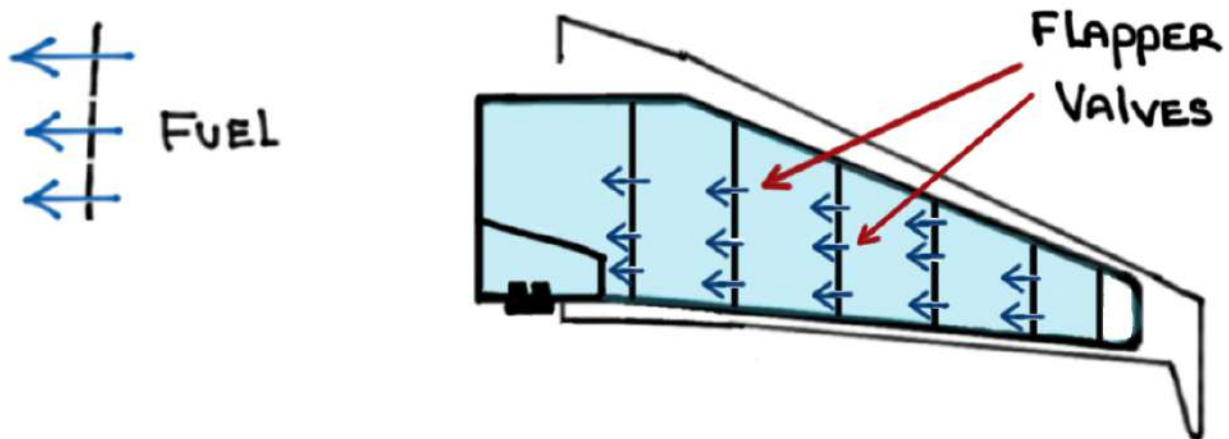

- Any fuel below the flapper valves moves towards the FUEL HOPPERS through small orifices called WEEP HOLES

- The PLENUM, also known as the VENT TANK, CATCHES FUEL VENT SYSTEM DURING TRANSIENT MANEUVERS. This fuel is THEN DRAWN BACK INTO THE FUEL TANKS WHEN STABLE FLIGHT IS RESUMED
- The PLENUM also allows for a two (2) PERCENT FUEL EXPANSION

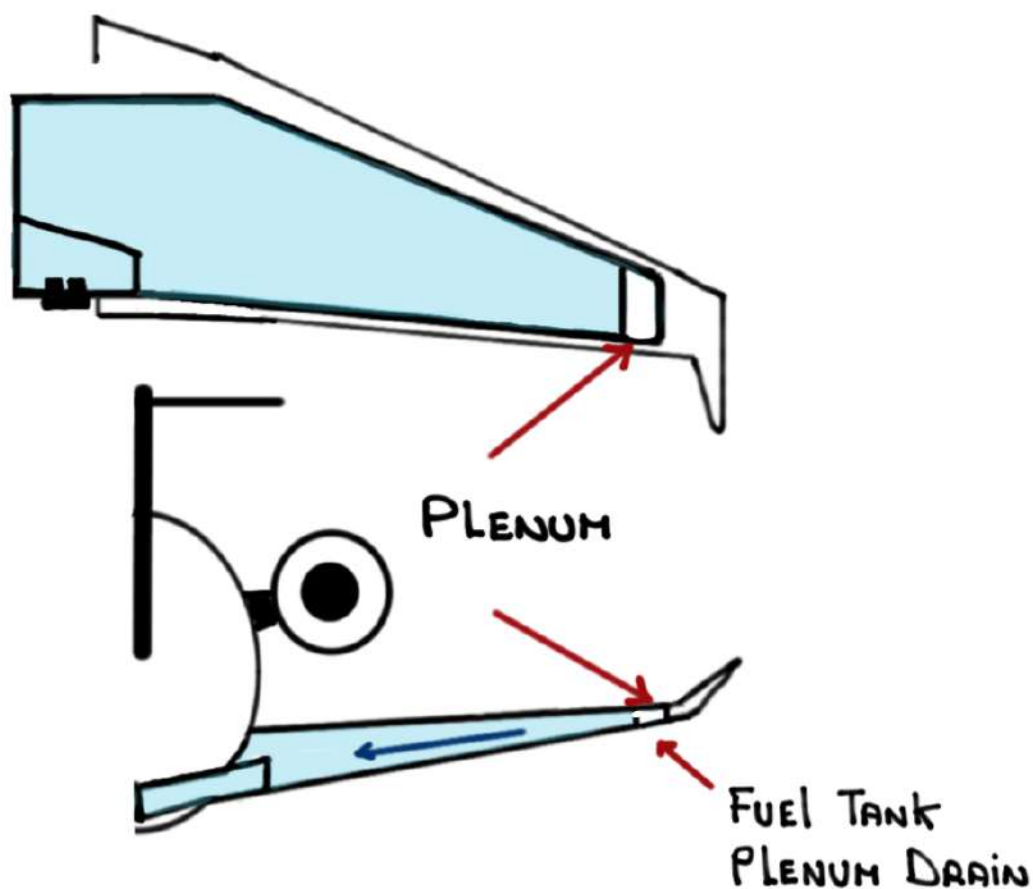

- The PLENUM should be DRAINED of any fuel PRIOR TO TAKEOFF

- The fuel tanks are vented (NACA vents) to provide positive internal pressure and to protect against over and under pressurization
- The fuel vent system is fully automatic and does not require electrical power
- The fuel vent system allows vapors and air to escape as fuel goes inside the tanks during refueling

PREVENTS wing RUPTURE (positive pressure)

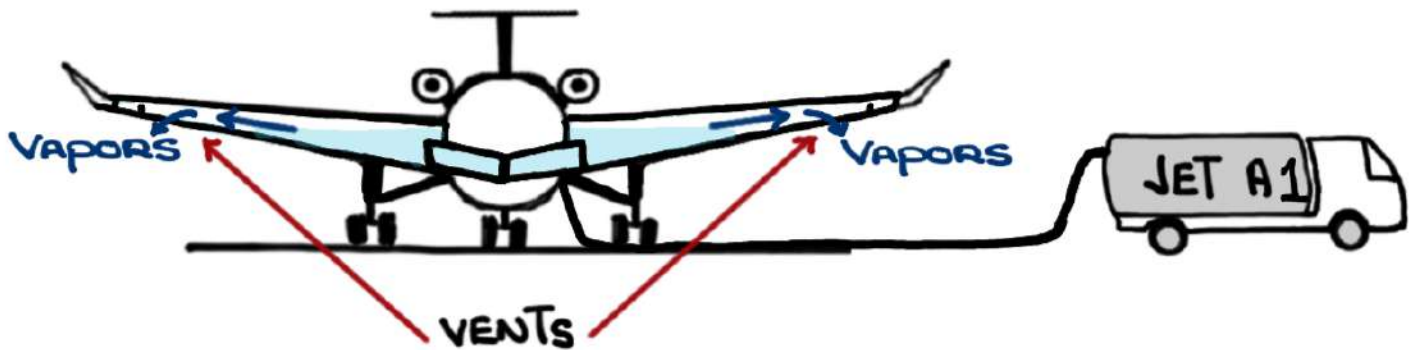

- The fuel vent system allows air to enter the fuel tanks as fuel is consumed during flight



PREVENTS wing collapse (negative pressure)

- THE HOPPER TANKS ARE SEGREGATED TANKS WITHIN THE WING TANKS

- THEY ARE LOCATED ADJACENT TO THE CENTERLINE RIB AT THE LOWEST POINT WITHIN THE WING TANK

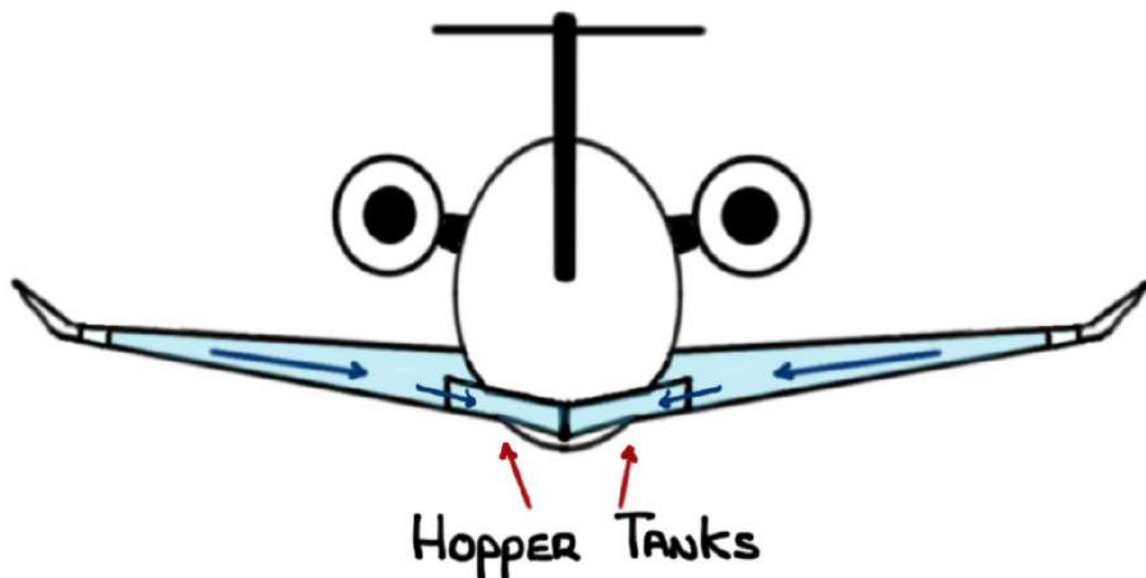
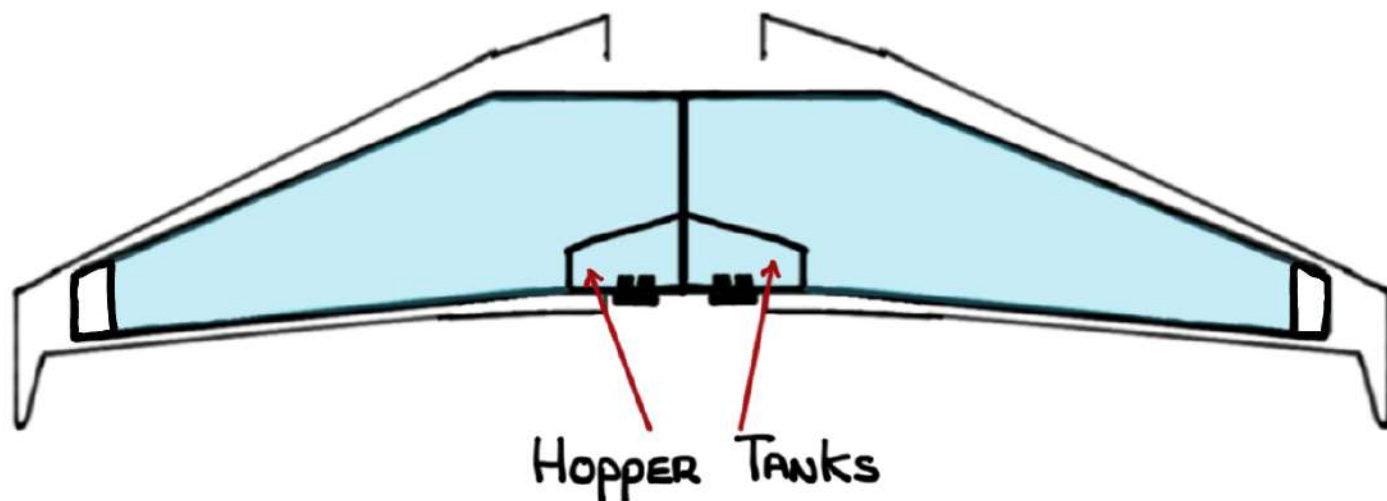

- IT IS FROM THE HOPPER TANKS THAT FUEL IS DRAWN TO FEED THE ENGINES AND APU

- The Hopper Tanks ARE KEPT full via:

① FLAPPER-Type VALVES (GRAVITY)

- THREE (3) flapper valves PER Hopper
- Allow GRAVITY flow of FUEL FROM wing TO Hopper

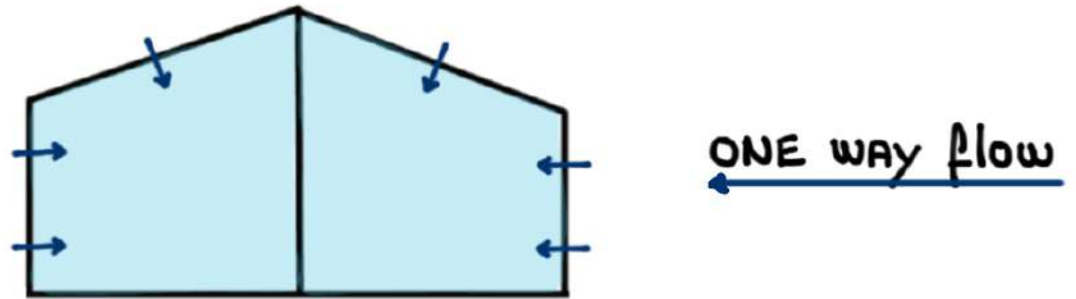

② EJECTOR pumps which DON'T HAVE MOVING PARTS.

They USE MOTIVE flow FROM FUEL boost pump PRESSURE TO DRAW FUEL FROM THE wing TANKS INTO Hopper TANKS

- DELIVER STEADY flow of FUEL FROM wing TO Hopper
- LOW PRESSURE, high volume pumps
- 4,450 pounds per hour

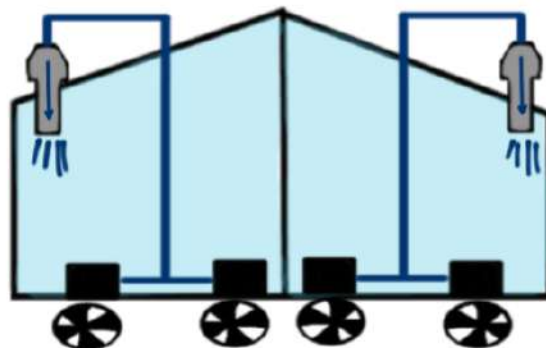

- HOPPER TANKS CAPACITY : 1170 lbs X 2
- L-R fuel level low : < 750 lbs
- EXCESS fuel in THE HOPPERS CAN spill back INTO THE wing TANKS VIA A GAP ABOVE THE Hopper walls

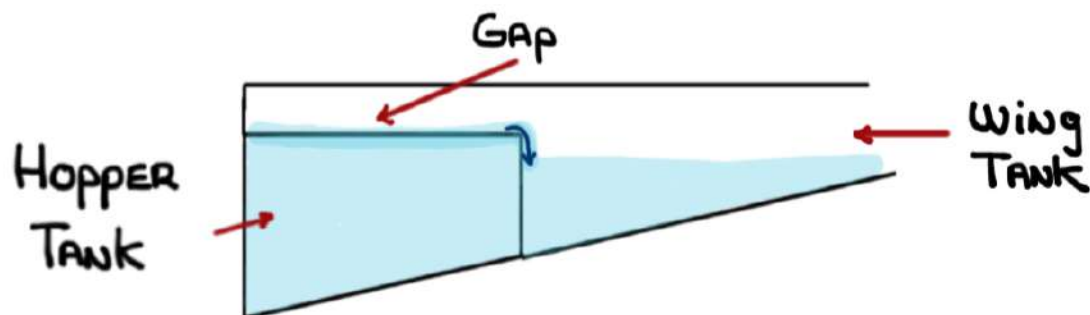

- THE HOPPER TANKS CONTAIN THE ELECTRICALLY-DRIVEN BOOST PUMPS which deliver LOW PRESSURE (25 psi) fuel TO THE ENGINES AND APU

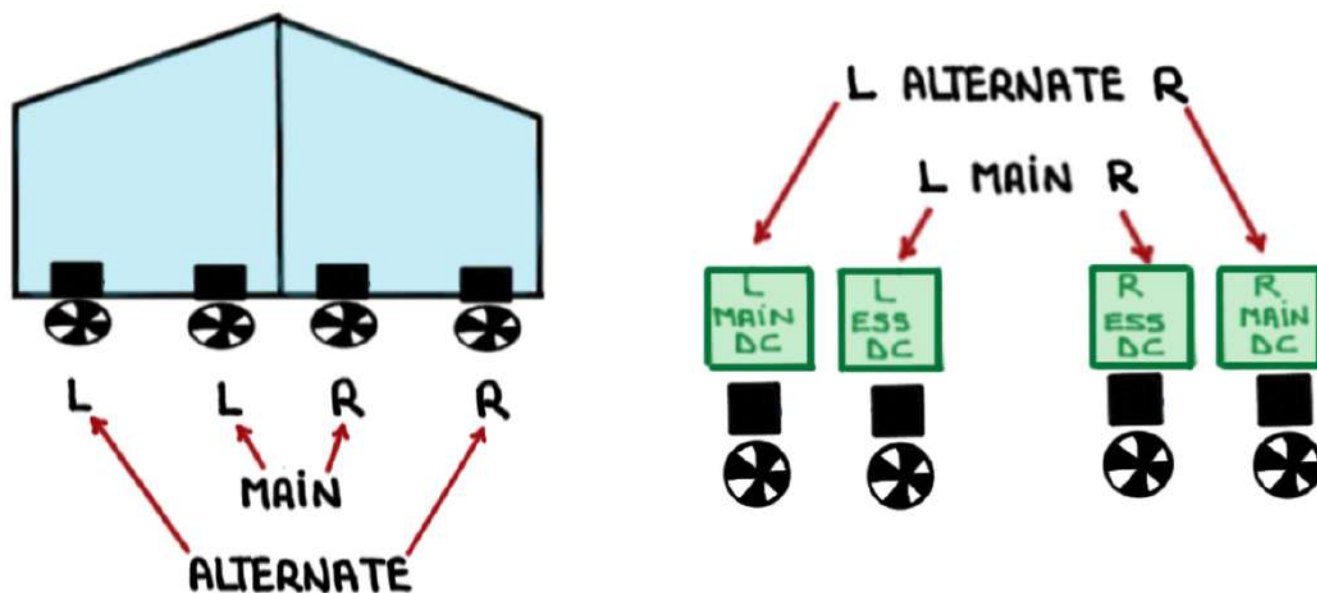

- Two (2) boost pumps per Hopper
- Boost pumps ARE IDENTICAL AND INTERCHANGEABLE
- LOCATED in the wheel well AND ATTACHED TO THE AFT PORTION of the Hopper

- Two (2) MAIN powered by RESPECTIVE
- Two (2) ALTERNATE powered by RESPECTIVE



- Without Boost pump pressure The engines will:

- ① < 20,000' = SUCTION FEED
- ② ≥ 20,000' = RUN ERRATICALLY AND FLAMEOUT

- Each boost pump draws < 25 amps
- All operable boost pumps MUST BE SELECTED ON for all PHASES of flight UNLESS fuel balancing is in PROGRESS OR AS DIRECTED by the checklist

- REAR wing beam boost pumps

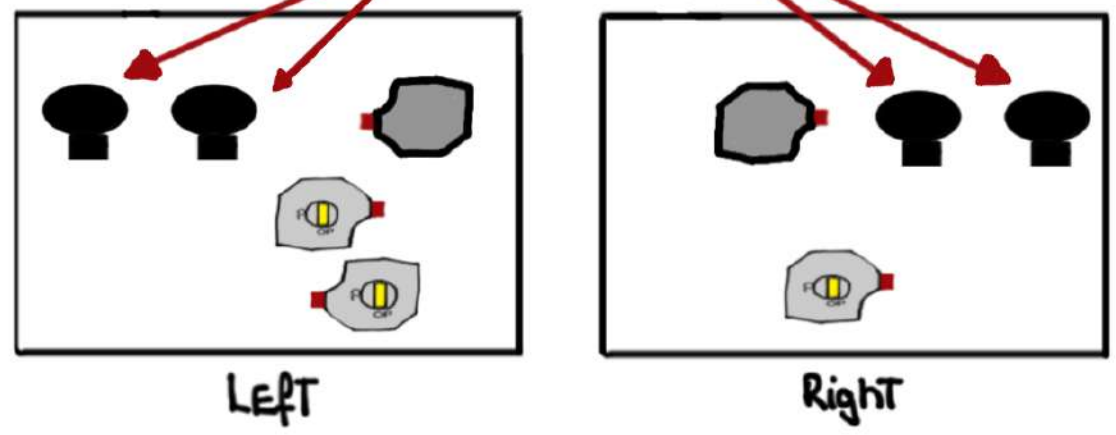

- THE HOPPER TANKS CONTAIN THE HYDRAULIC fluid-TO-fuel HEAT EXCHANGERS

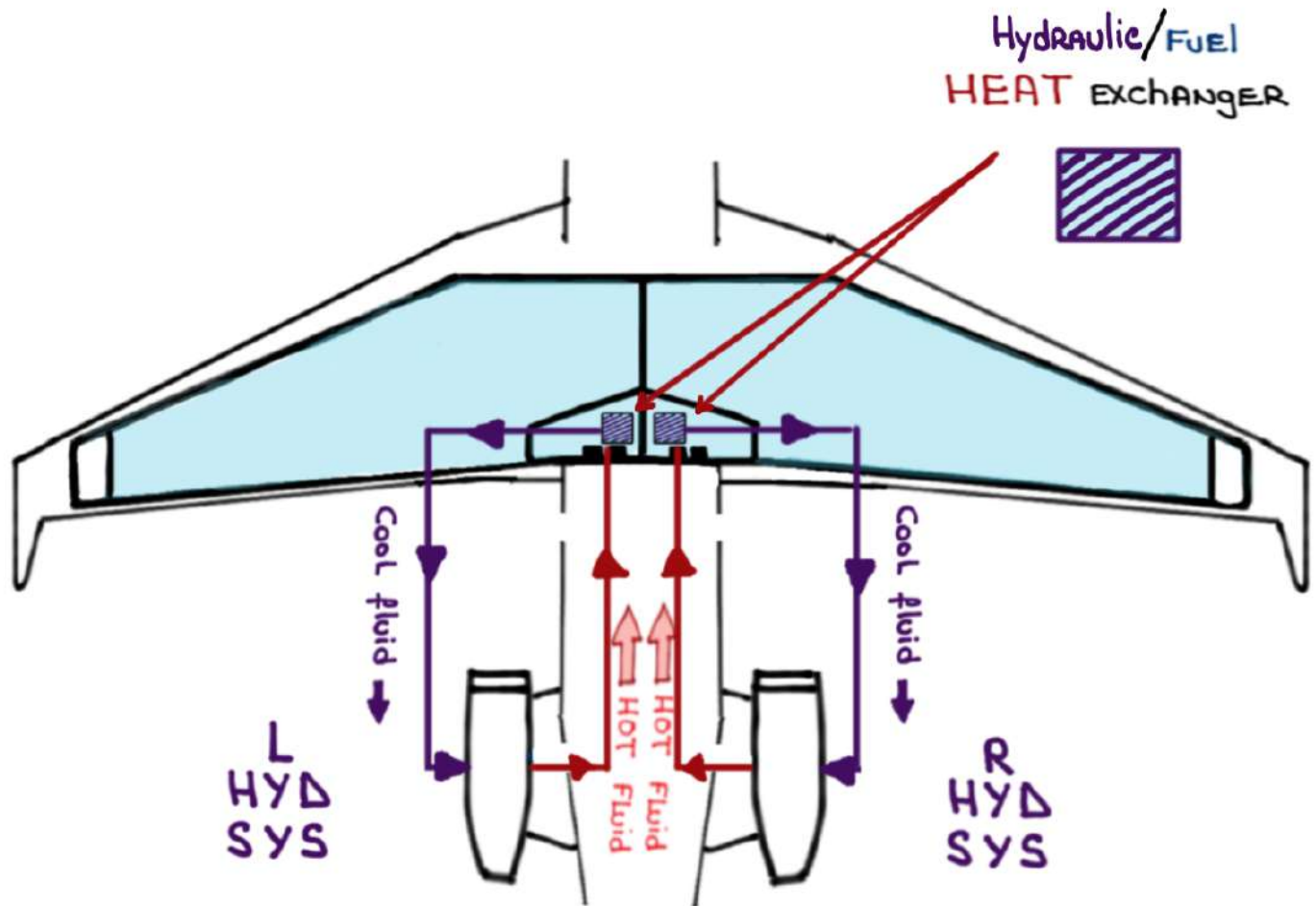

THE HEAT EXCHANGER UNIT IS INSIDE THE ONSIDE FUEL HOPPER. **HOT** HYDRAULIC fluid flows CONTINUOUSLY THROUGH THE HEAT EXCHANGER WITHOUT pilot input

HOT HYDRAULIC fluid is cooled while **COLD** fuel in THE HOPPER is WARMED up

FUEL SHUTOFF VALVES

- THERE ARE THREE (3) FUEL SHUTOFF VALVES (SOV)

- ① LEFT ENGINE
- ② RIGHT ENGINE
- ③ APU

- LOCATED IN THE WHEEL WELL AND ATTACHED TO THE AFT PORTION OF THE HOPPER
- MAIN ENGINE SOV IS OPERATED BY THE RESPECTIVE **FIRE** HANDLE IN THE COCKPIT AND POWERED BY ITS RESPECTIVE DC ESS BUS

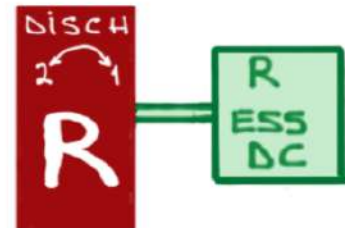
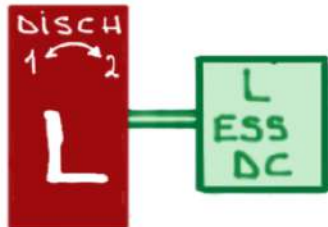

- MAIN ENGINE SOV POSITION INDICATOR - WHEEL WELL

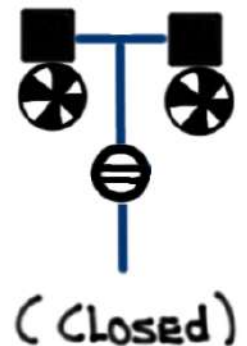
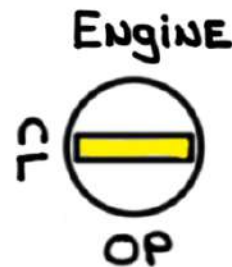
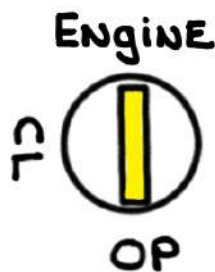
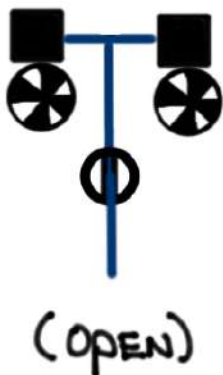

- APU SOV is controlled by The APU Electronic Control Unit (ECU)

- APU SOV position indicator - wheel well (Left)

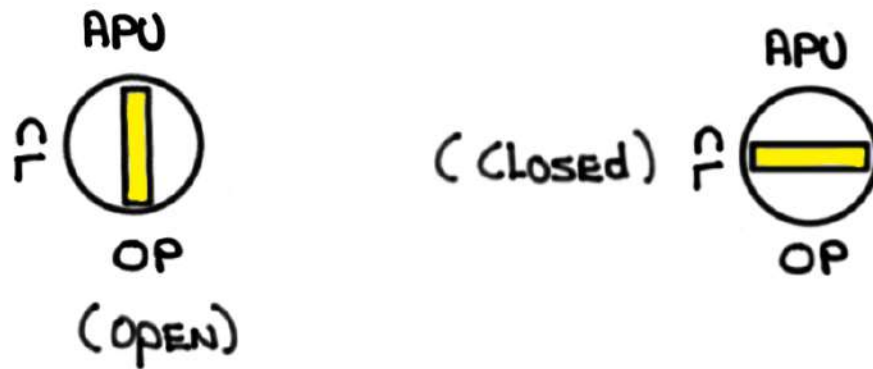

- REAR wing BEAM

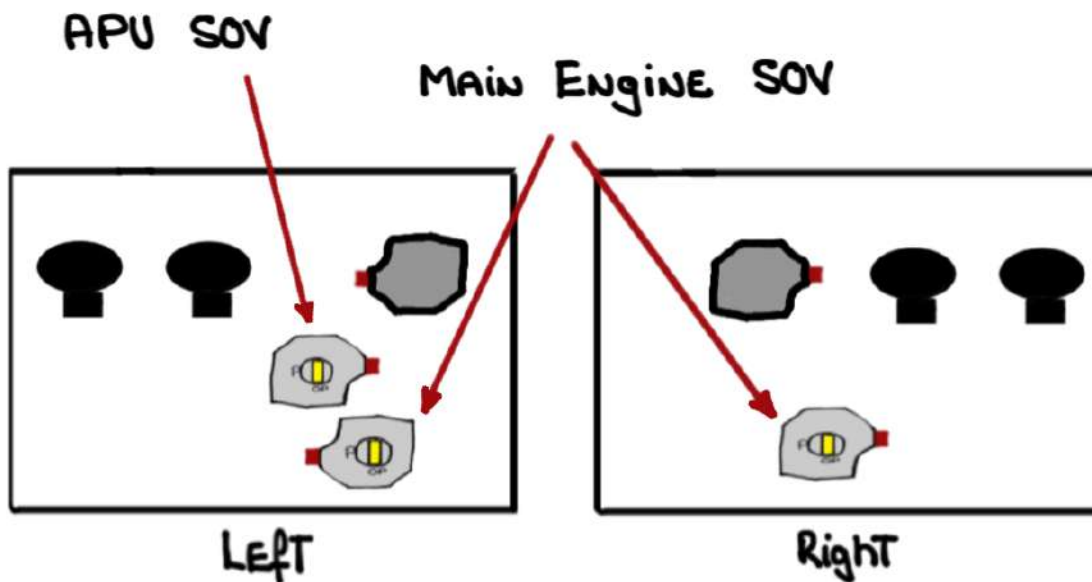

HEATED FUEL RETURN SYSTEM (HFERS)

- The HFERS PREVENTS FUEL TANK TEMPERATURES FROM GETTING TOO COLD DURING LONG RANGE, HIGH ALTITUDE FLIGHTS
- The HFERS SENDS FUEL HEATED BY THE FUEL OIL HEAT EXCHANGER (FOHE) INTO THE WING TANKS
- The FOHE COOLS DOWN **HOT** ENGINE OIL AND WARMS UP **COLD** FUEL

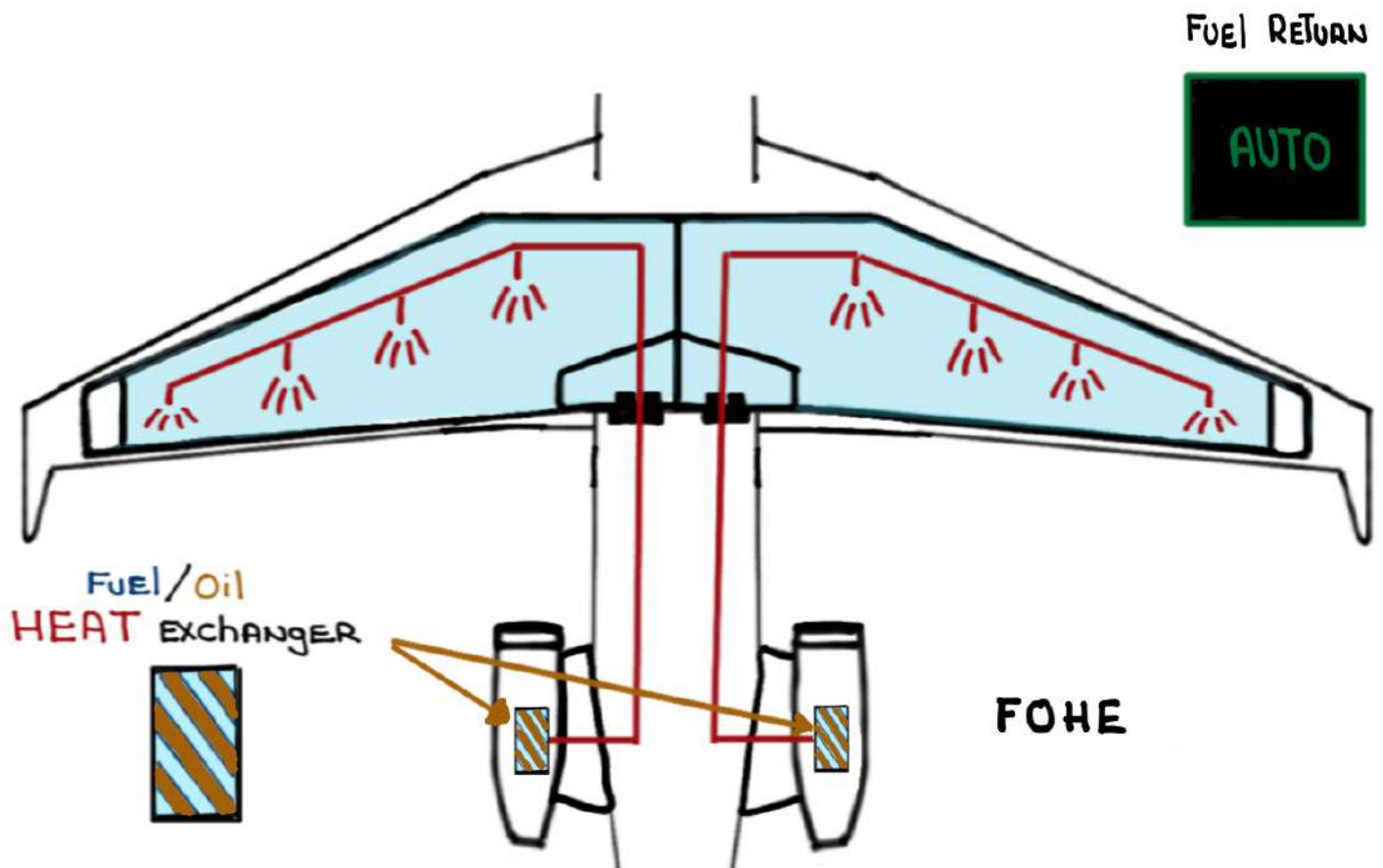

- Controlled by FADEC
- AUTO ON: 0°C AUTO OFF: 10°C
- THREE (3) gallons of HEATED FUEL @ 50°C PER MINUTE
- HFRS is inhibited under the following conditions:
 - a) FUEL TANK TEMPERATURE > 10°C
 - b) CROSSFLOW VALVE OPEN
 - c) ENGINE THRUST LEVER SETTING AT HIGH POWER
 - d) HFRS switch selected OFF
 - e) ENGINE FIRE handle pulled/NOT STOWED
 - f) LOW FUEL PRESSURE/QUANTITY
 - g) FADEC HFRS inhibit ON
 - h) ENGINE FUEL FILTER blocked
 - i) ABNORMAL ENGINE INDICATION

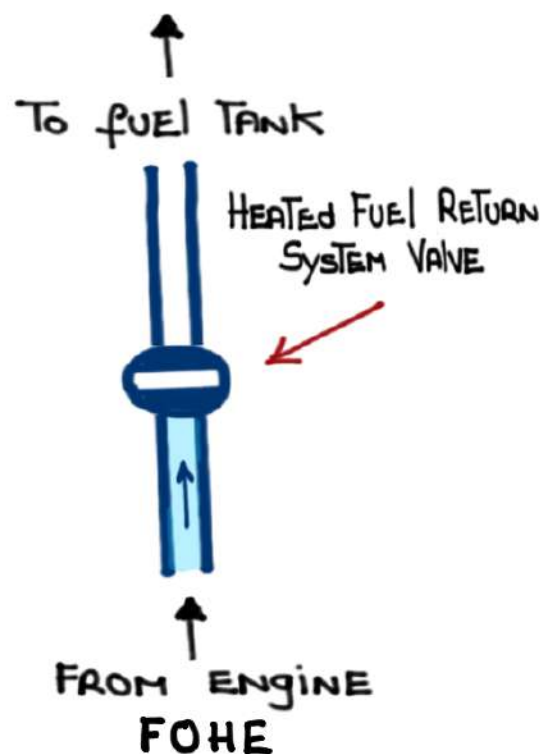

- FUEL TANK TEMPERATURE:

- **AMBER**

$< -37^{\circ}\text{C}$ $> 54^{\circ}\text{C}$

FUEL TANK TEMPERATURE

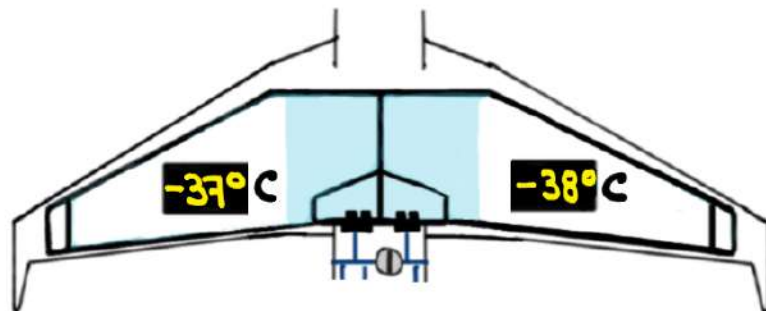

- **CYAN**

-36° OR -35°C

FUEL TANK TEMPERATURE

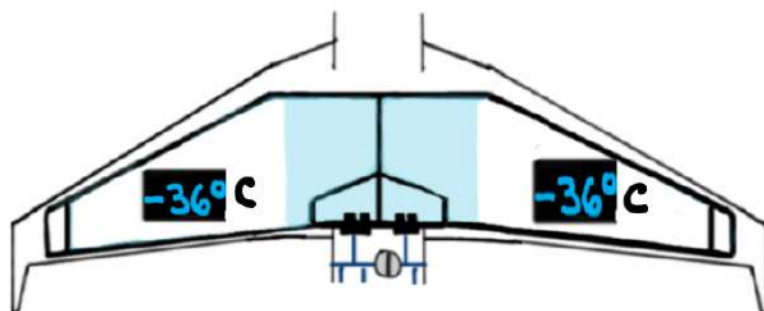

- **CYAN**

-30°C with $< 5,000$ lbs

FUEL TANK TEMPERATURE

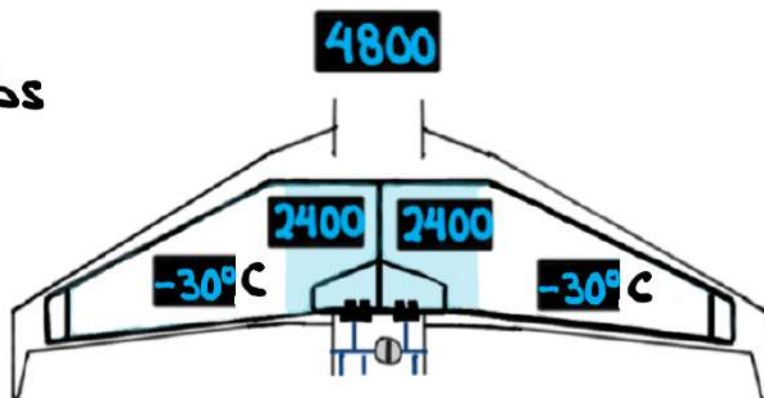

- ENGINE FUEL TEMPERATURE:

MINIMUM ENGINE FUEL TEMPERATURE FOR TAKEOFF POWER:

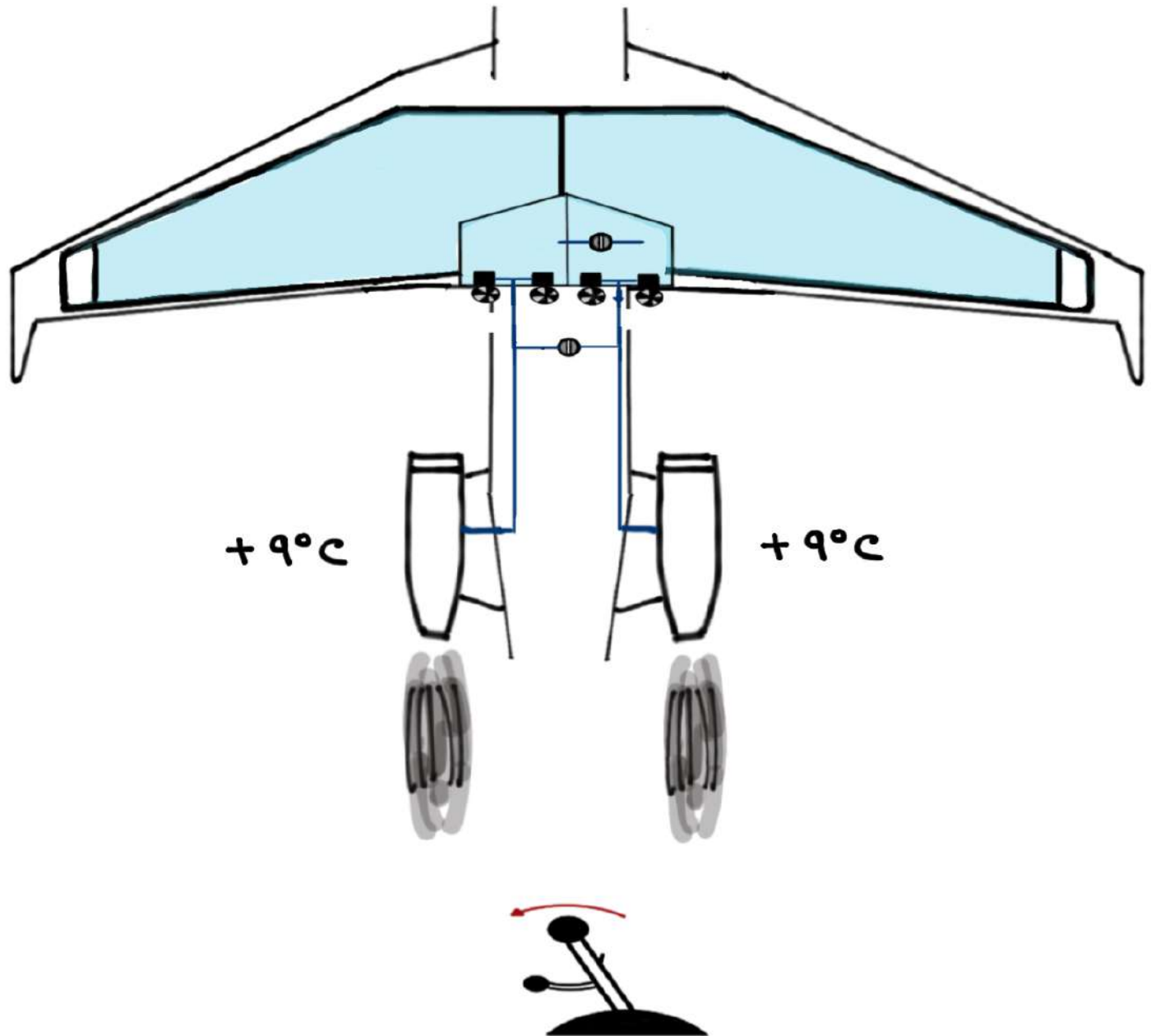

- If in flight with a fuel TANK TEMPERATURE of -30°C and $< 5,000$ lbs TOTAL REMAINING:

- DESCEND TO AN ALTITUDE WHERE THE SAT IS -60°C OR WARMER AND MAINTAIN A SPEED OF M.080 OR GREATER

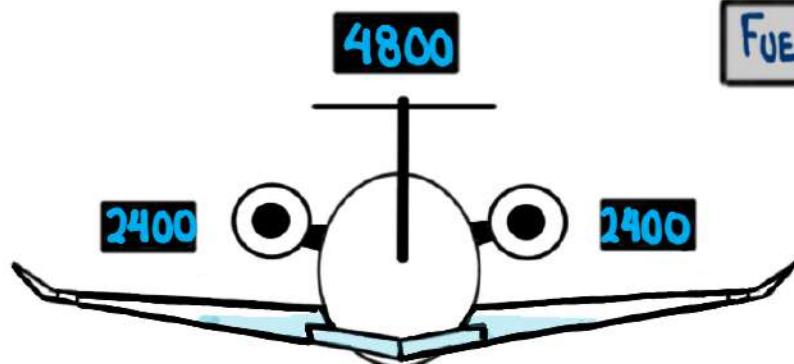

FUEL TANK TEMPERATURE

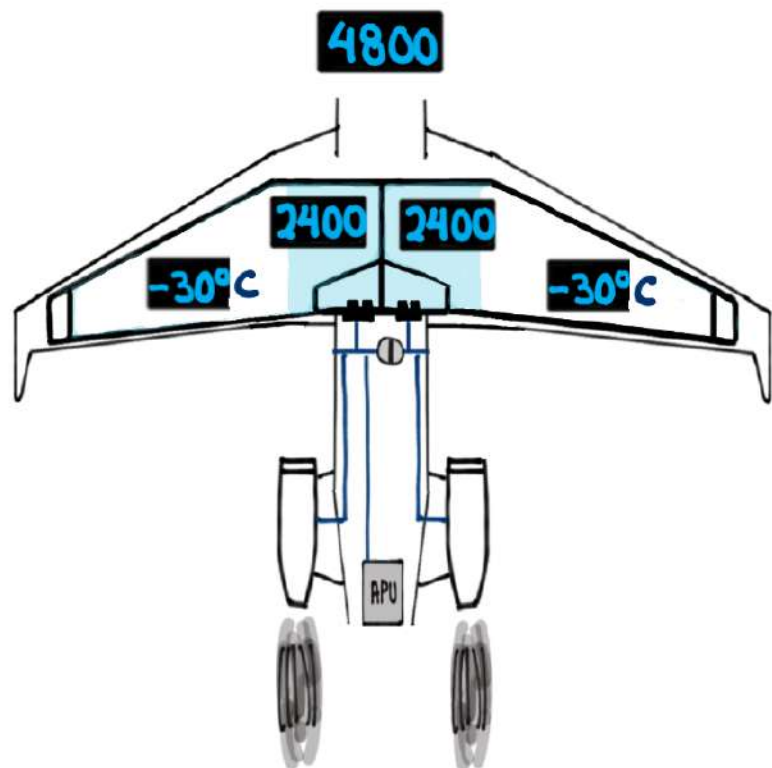

SAT -60°C



SAT -55°C

FUEL ImBALANCE

- FUEL ARROWS APPEAR WHEN A FUEL ImBALANCE CONDITION EXISTS
- ARROW COLORS INDICATE SEVERITY LEVEL
- HIGHER SIDE HIGHER ARROW

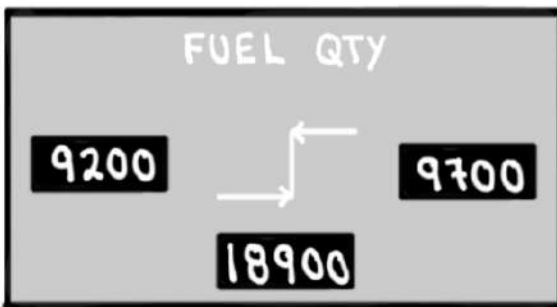

500 lbs imbalance

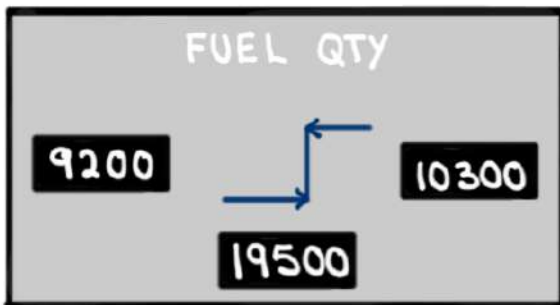

1,000 lbs imbalance in flight

FUEL ImBALANCE CAS MESSAGE

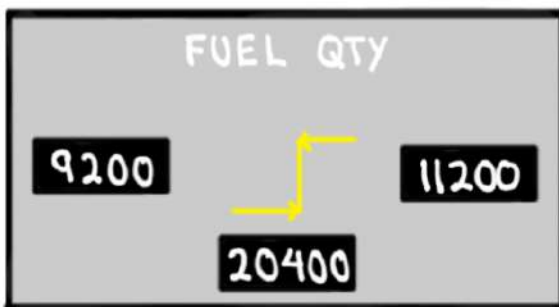

1,000 lbs imbalance **GROUND**

2,000 lbs imbalance **Inflight**

FUEL ImBALANCE CAS MESSAGE

- IN THE EVENT OF A FUEL IMBALANCE CONDITION TWO METHODS ARE AVAILABLE TO BALANCE FUEL:

① INTERTANK VALVE:

- WHEN OPEN IT ALLOWS FUEL TO GRAVITY FLOW BETWEEN THE RIGHT AND LEFT FUEL TANKS VIA THE HOPPERS
- APPROXIMATELY $\frac{1}{2}$ ZOID DISPLACEMENT WHEN APPLYING RUDDER TRIM

② CROSSFLOW VALVE:

- WHEN SELECTED OPEN AND BOOST PUMPS ON LIGHT SIDE ARE SELECTED OFF IT ALLOWS FUEL FROM HEAVY TANK TO FEED BOTH ENGINES

• REAR WING BEAM

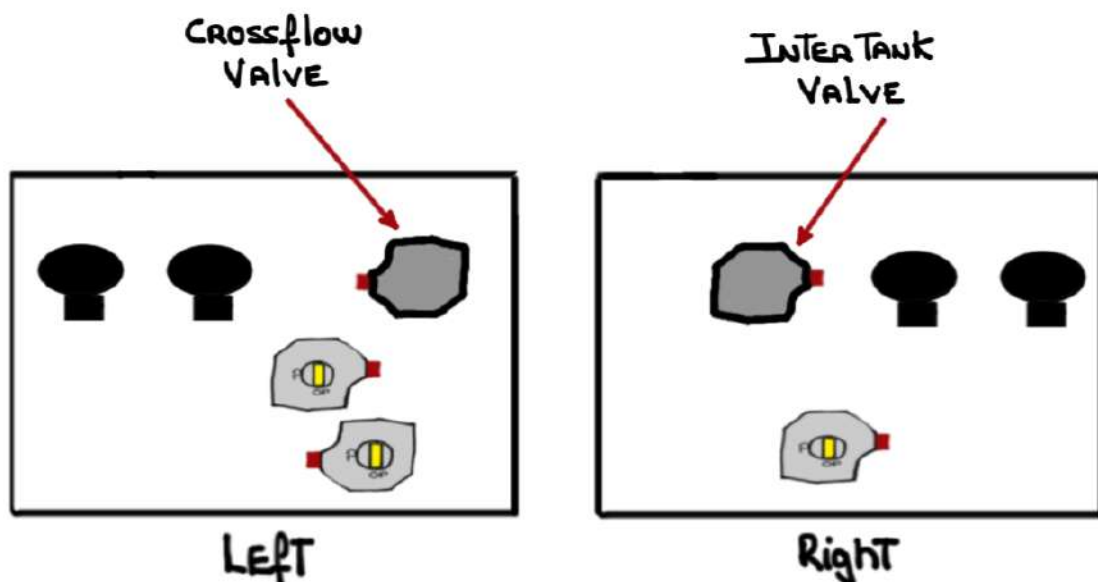

METHOD 1: INTER TANK

① AUTOPILOT ON, LEVEL flight

② MANUALLY ADJUST RUDDER TRIM TOWARDS THE HEAVY wing

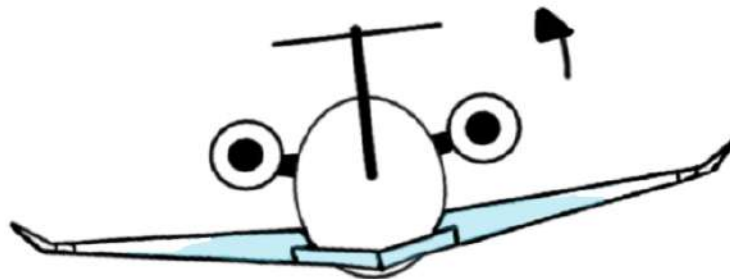

③ OPEN INTER TANK VALVE AND MONITOR fuel progress

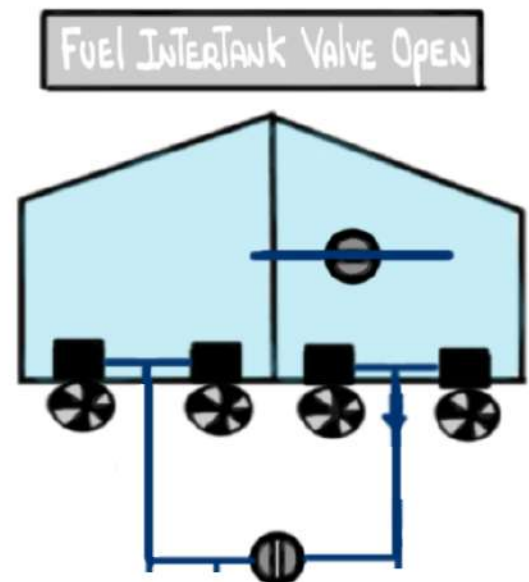
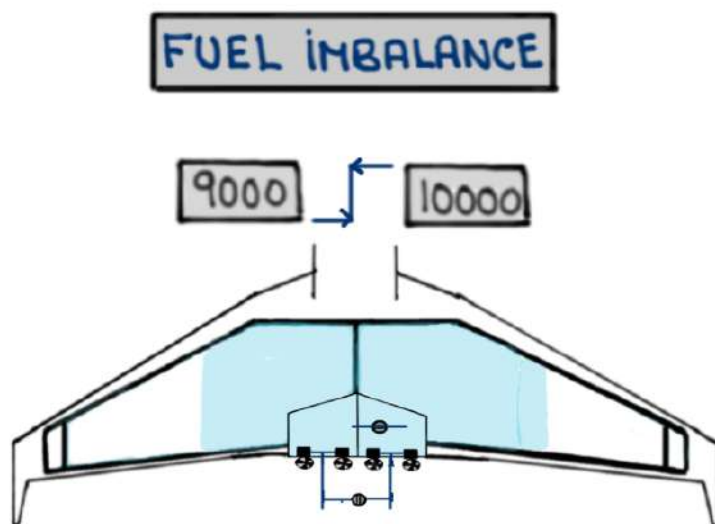

④ CLOSE INTER TANK VALVE when within **200** lbs or so



⑤ RETRIM RUDDER

METHOD 2: Crossflow

① OPEN Crossflow valve



FUEL CROSSFLOW VALVE OPEN



② TURN OFF boost pumps, ONE AT A TIME, ON light wing

FUEL IMBALANCE

9000 ← 10000

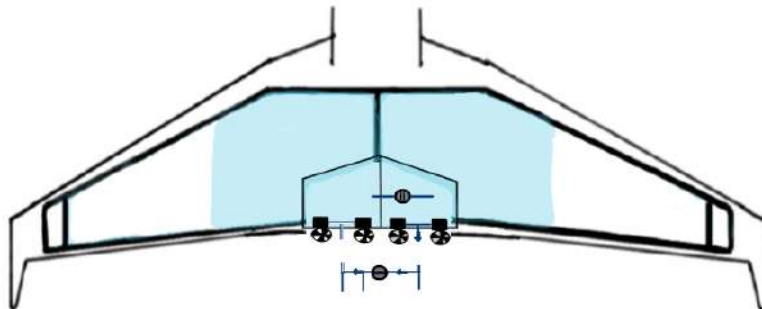

L ALT Pump L MAIN Pump R MAIN Pump R ALT Pump

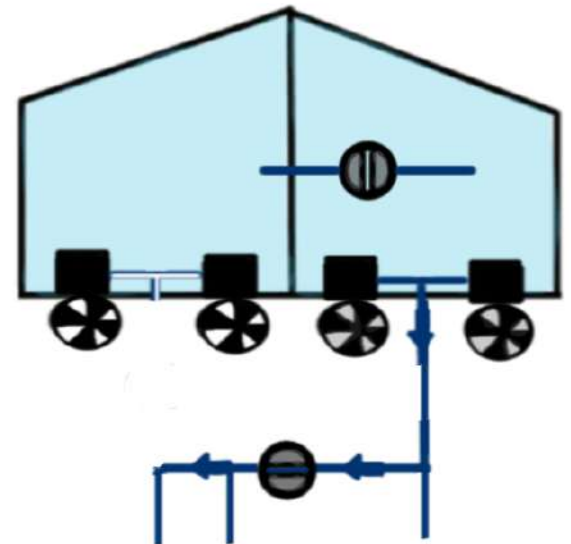

③ TURN ON boost pumps

④ CLOSE Crossflow valve when desired balance is achieved



9450 → 9550

- THE INTER TANK VALVE AND THE CROSSFLOW VALVE HAVE A FIVE (5) MINUTE TIMER

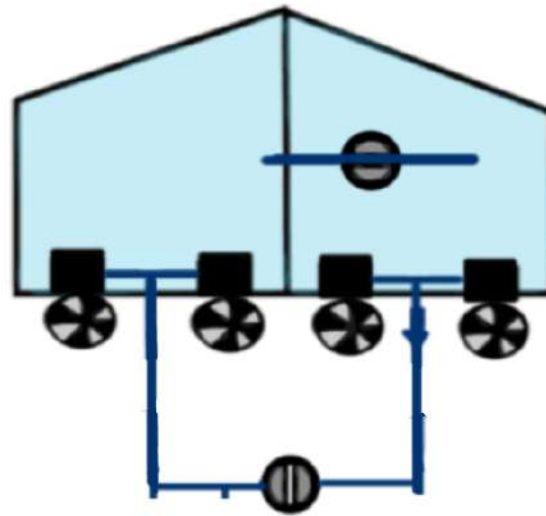

> 00:05 MINUTES

FUEL INTER TANK VALVE OPEN

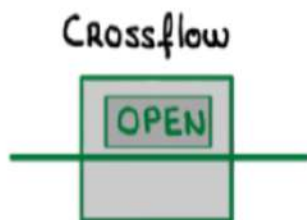
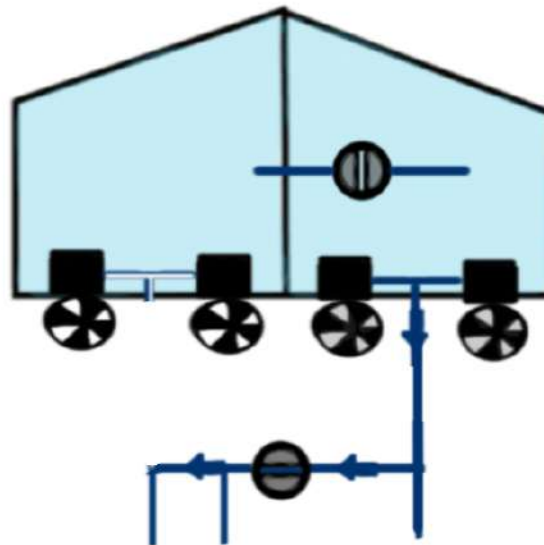

> 00:05 MINUTES

FUEL CROSSFLOW VALVE OPEN

- MAXIMUM FUEL Imbalance

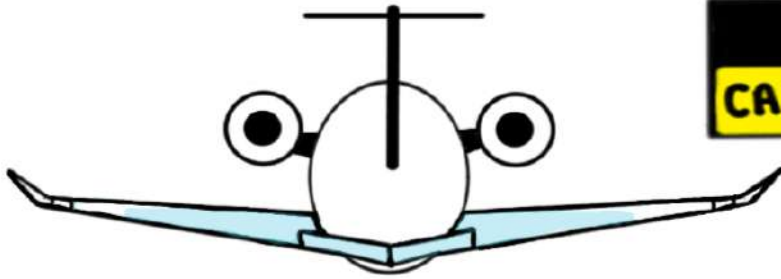

CAUT

FUEL ImBALANCE

CAUT

Inflight: 2,000 lbs.

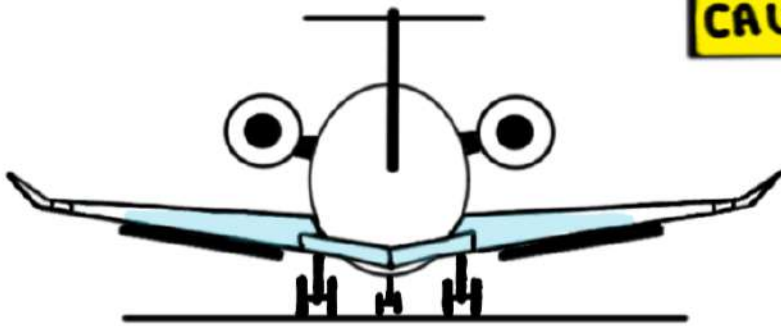

CAUT

FUEL ImBALANCE

CAUT

TAKEoff: 1,000 lbs.

REFUELING OPERATIONS

(PRESSURE / GRAVITY)

5,000 lbs

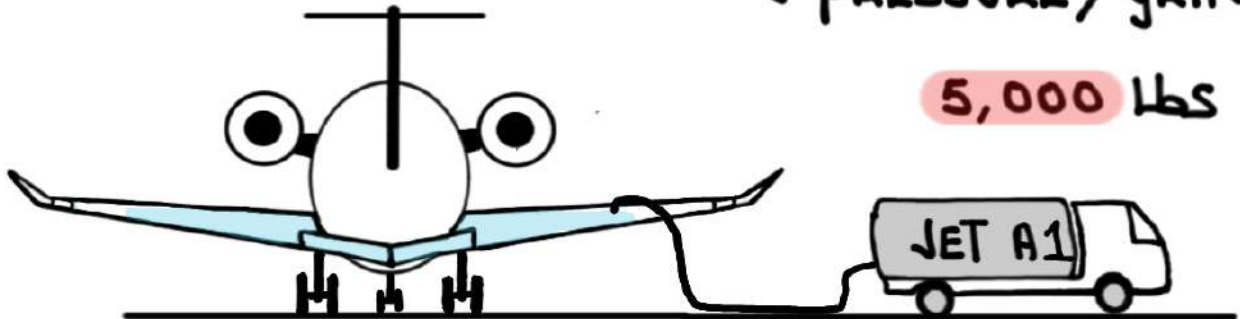

ENGINE FUEL SYSTEM

- METERED FUEL FROM TANKS' boost pumps TO NOZZLES
- INTRODUCTION of FUEL is CONTROLLED BY THE EEC
- LOW PRESSURE FUEL COMING FROM THE WINGS
- HIGH PRESSURE FUEL COMING FROM THE FUEL METERING UNIT (FMU)

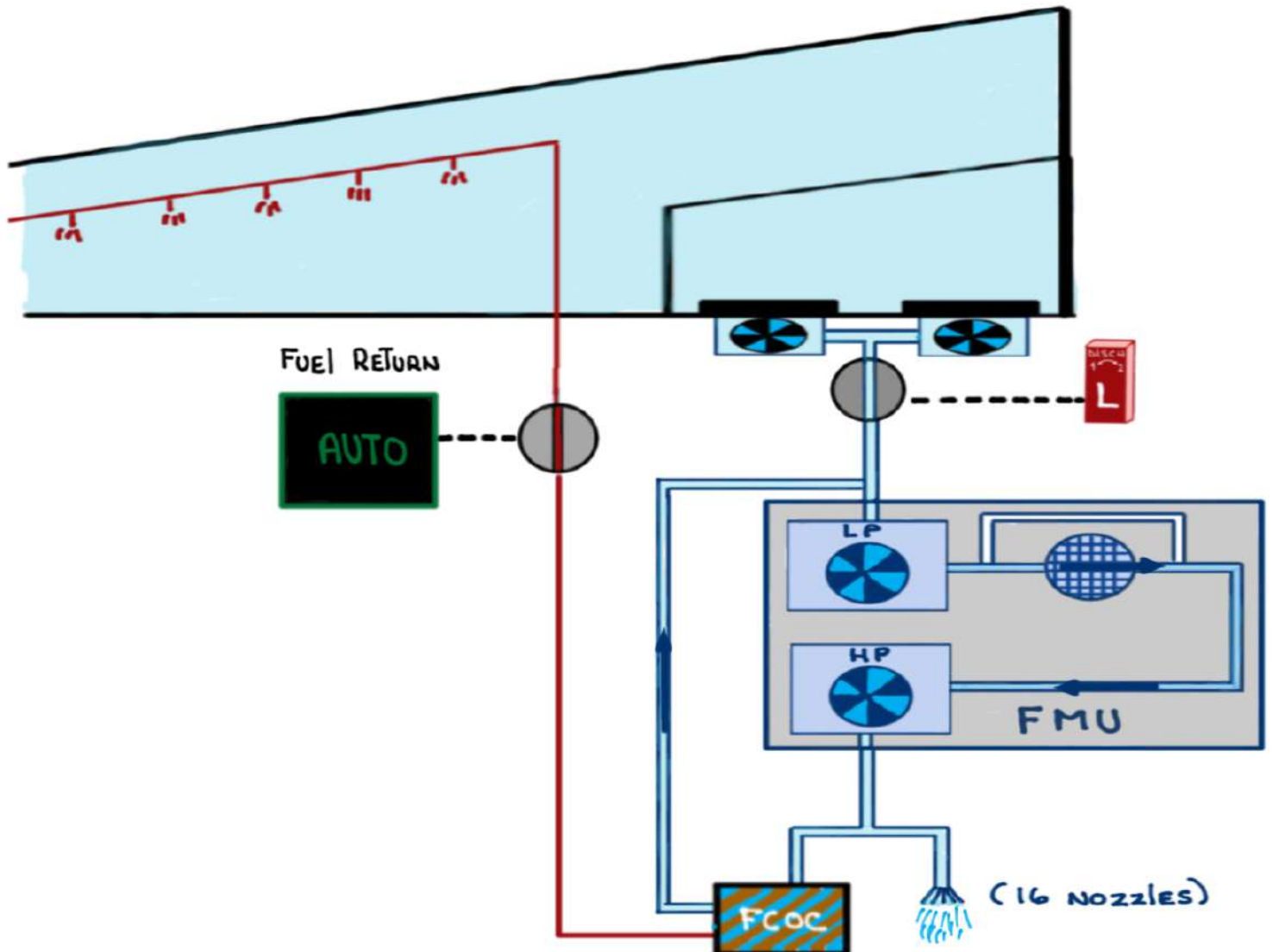

- As Thrust Levers are advanced or retarded the EEC commands the FMU to modulate fuel to nozzles

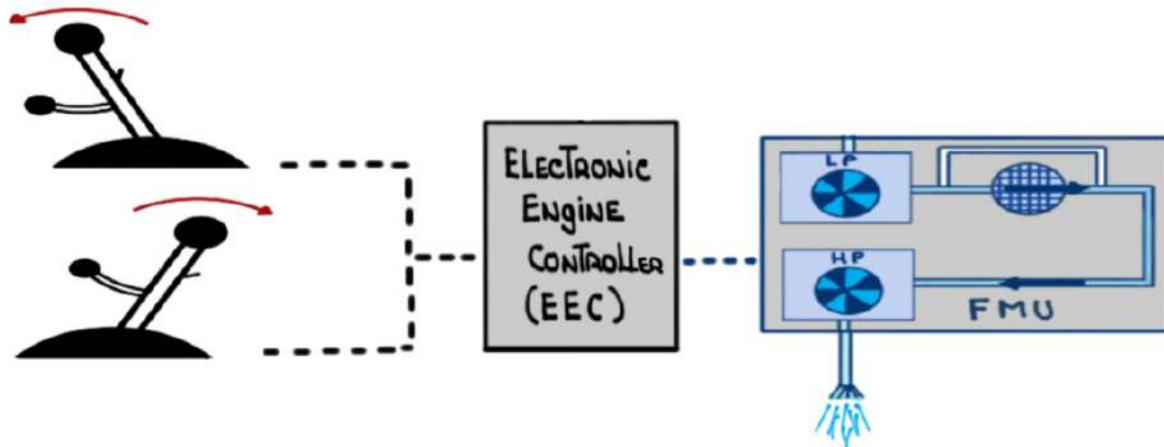

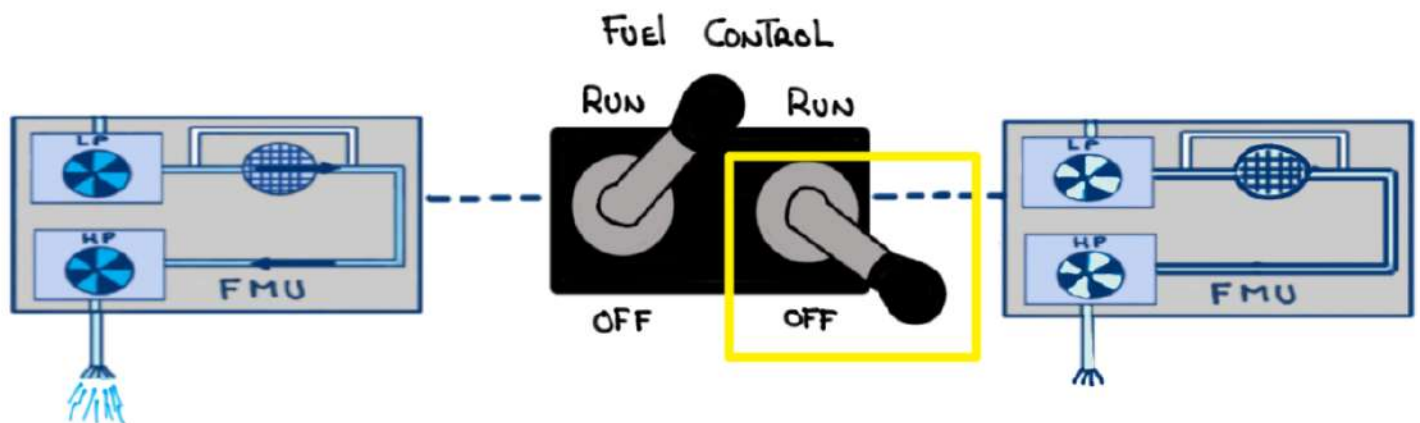

- Placing a fuel control switch to OFF closes FMU
All fuel is cutoff to the fuel nozzles and the engine shuts down

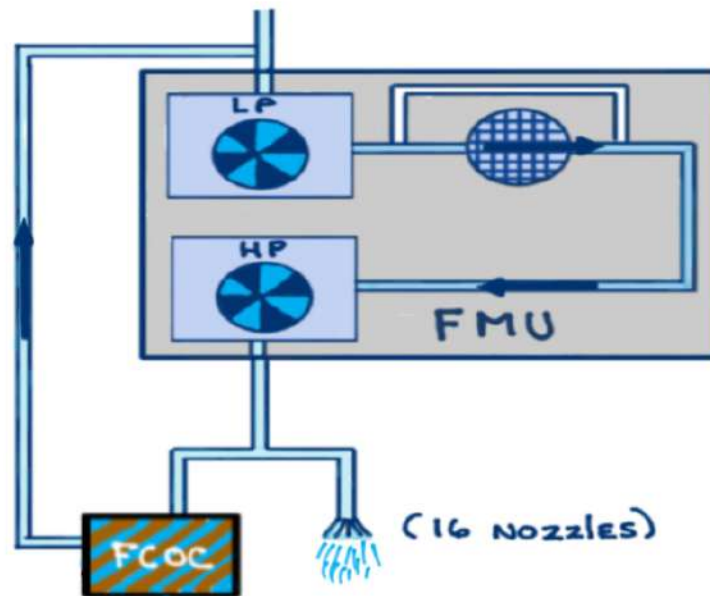

- The FMU contains two (2) internal pumps:

- Low pressure (LP) 1st stage →
 - High pressure (HP) 2nd stage →
-



- The LP and HP pumps are driven by the engine accessory gearbox
- A fuel filter RECEIVES fuel from the 1st stage LP pump and REMOVES debris and contaminants
- A filter bypass valve ensures CONTINUAL fuel flow to the engine if filter is blocked
- Excess fuel is recirculated through the **FUEL/OIL** heat exchanger 

APU FUEL Supply

FUEL is NORMALLY supplied FROM THE LEFT FUEL MANIFOLD BUT IT CAN ALSO BE SUPPLIED FROM THE RIGHT MANIFOLD by TEMPORARILY opening THE CROSSFLOW VALVE

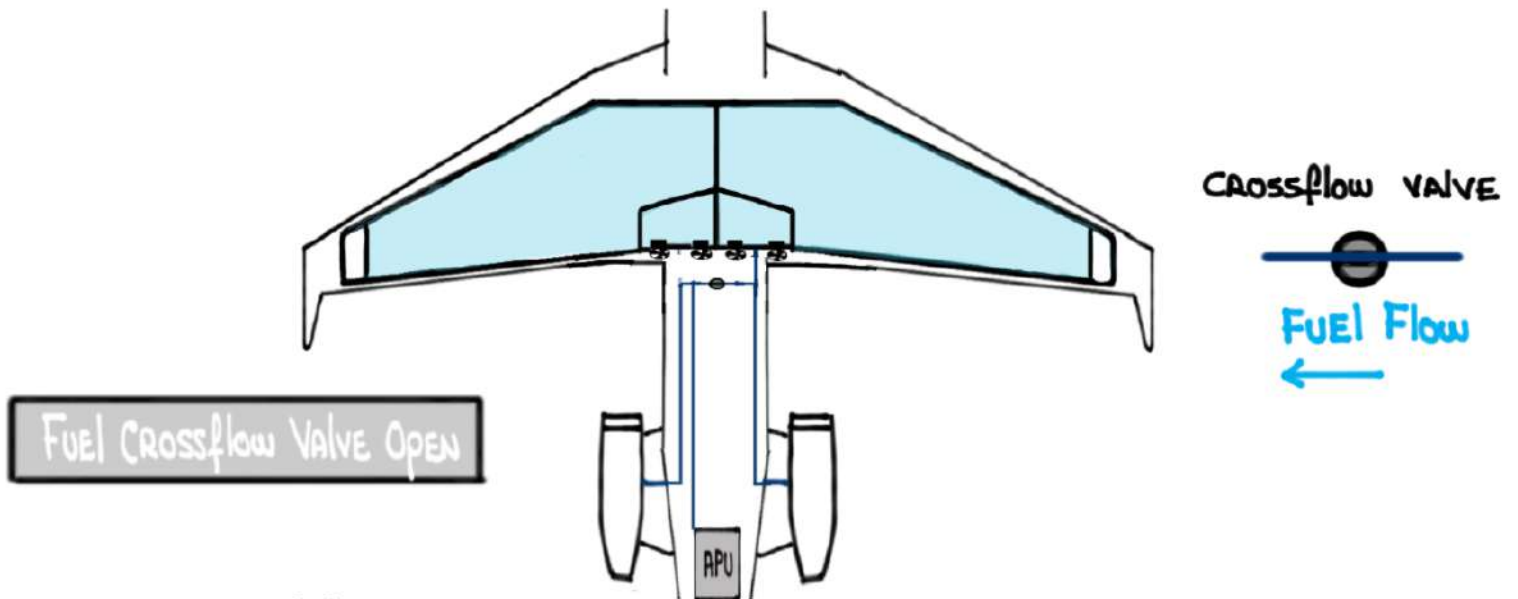

FUEL CROSSFLOW VALVE OPEN

L MANifold
To
APU

R MANifold
To
APU

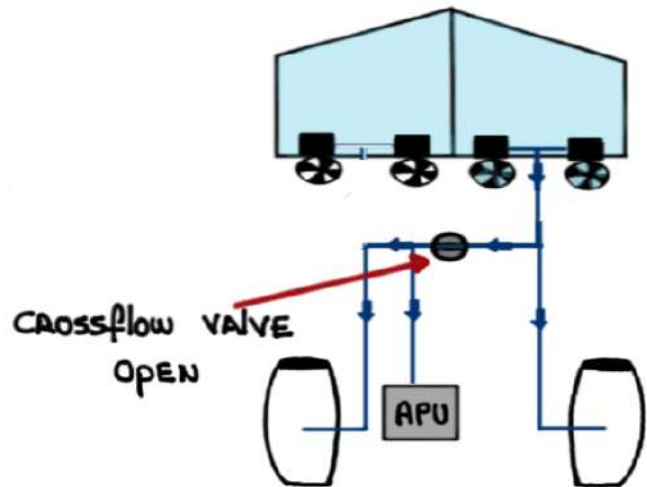
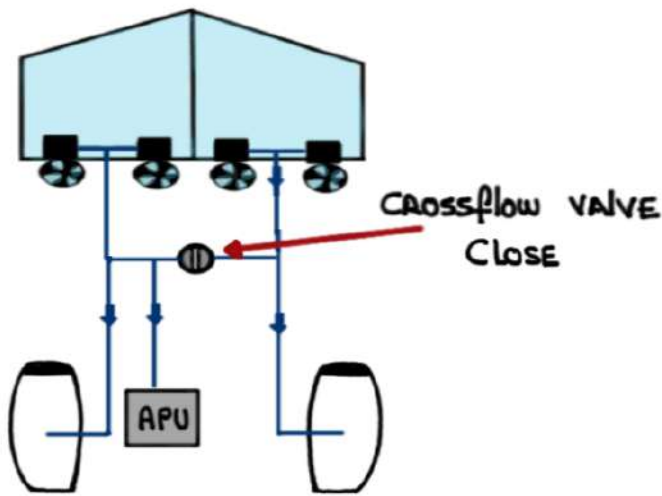

FUEL FILTRATION

THE FUEL FILTRATION SYSTEM PREVENTS CONTAMINANTS FROM ENTERING THE WING TANKS DURING OVERWING GRAVITY REFUELING

① GRAVITY FUELING ADAPTER

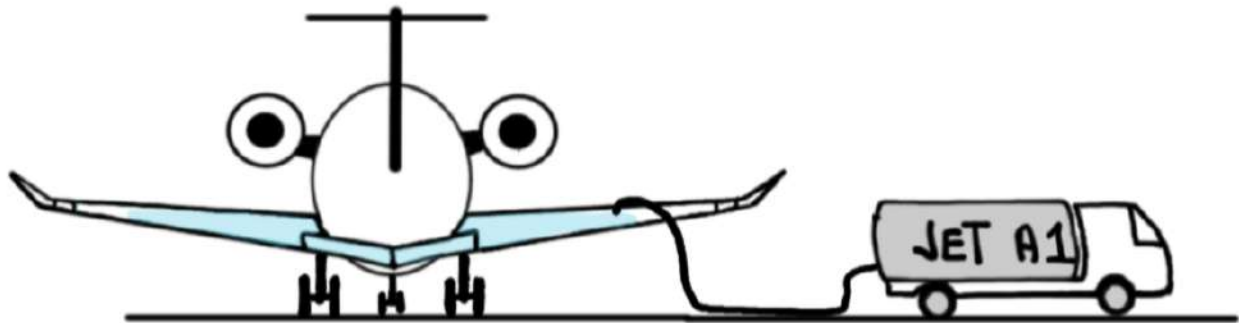
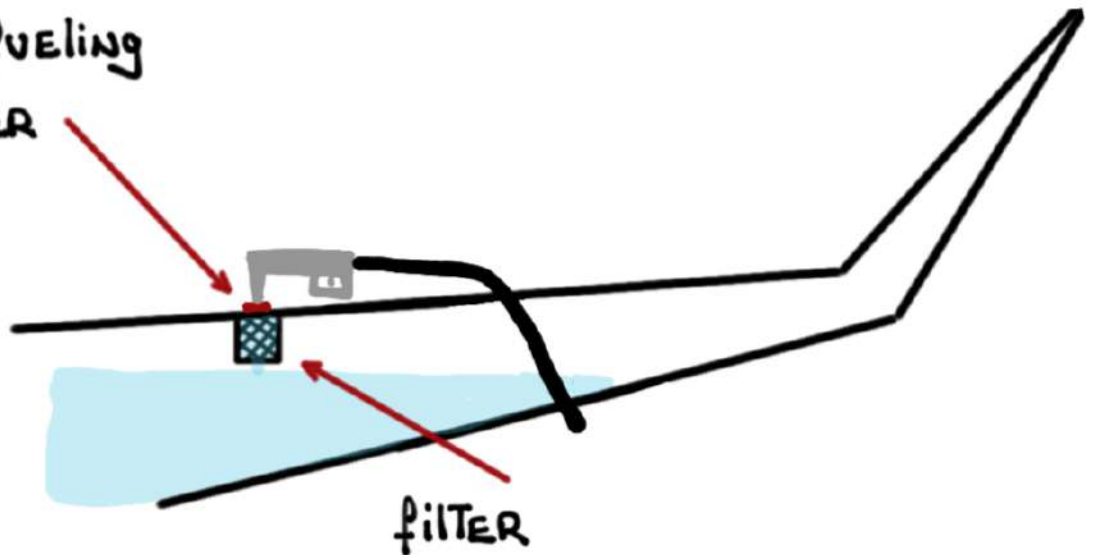

filtration is also accomplished AT:

② The inlets of all four (4) boost pumps

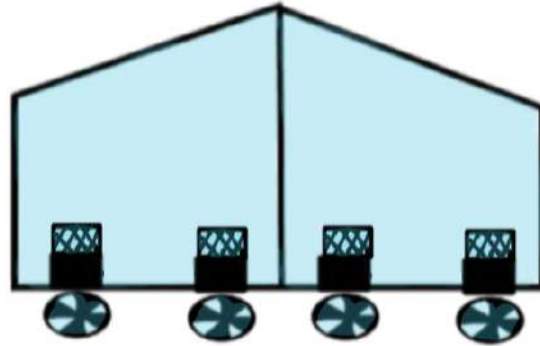

③ Prior To The HP pump (LP filter)

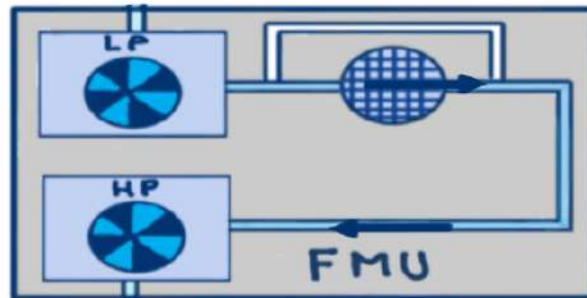

- Impending blockage of indicated LP filter

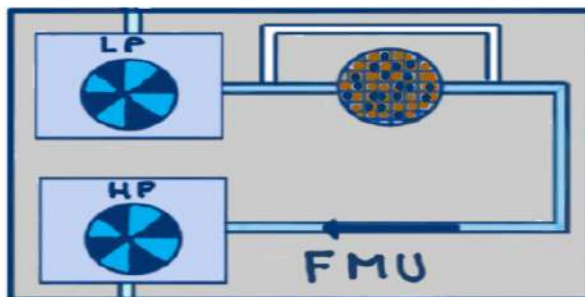

L-R FUEL FILTER

- FUEL IS BYPASSING INDICATED FILTER OR IMPENDING BLOCKAGE / BYPASSING OF BOTH LP FILTERS

L-R FUEL FILTER

LEFT ENGINE

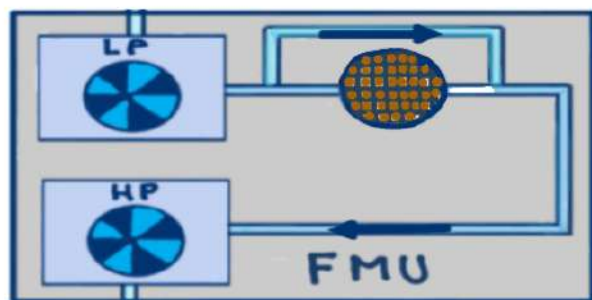

RIGHT ENGINE

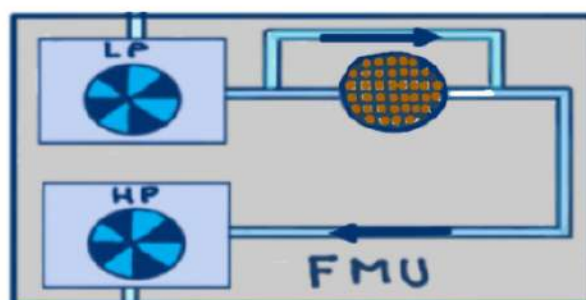

RAT OPERATIONS

When operating with The **RAT** The following fuel system components remain operative

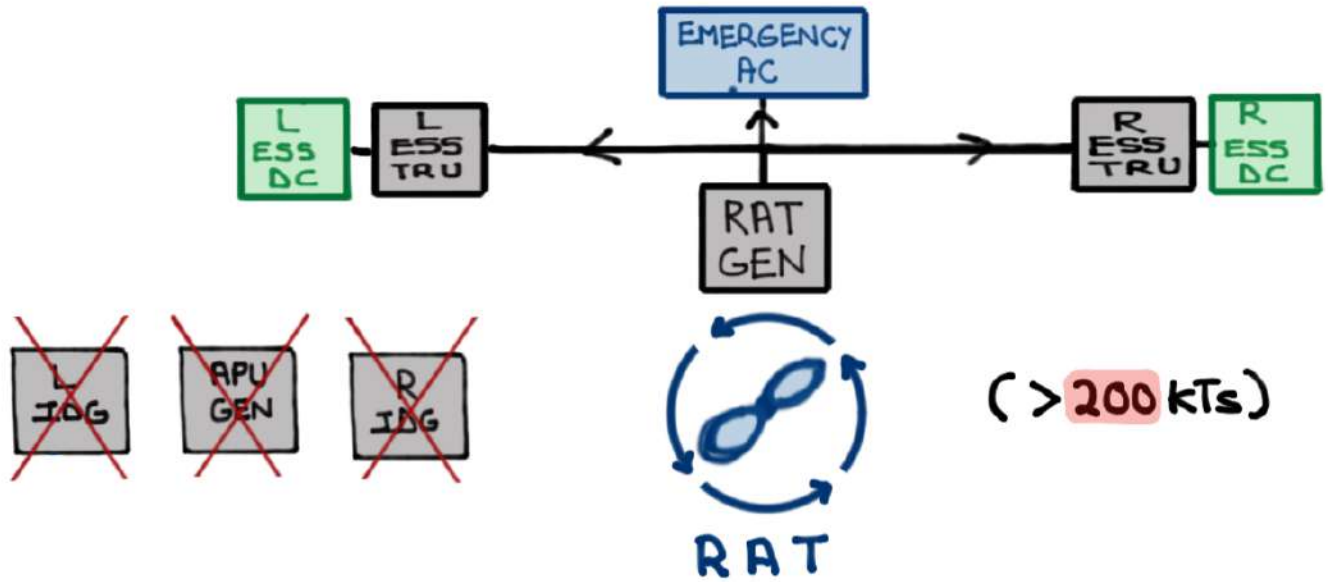

RAT GENERATOR ON

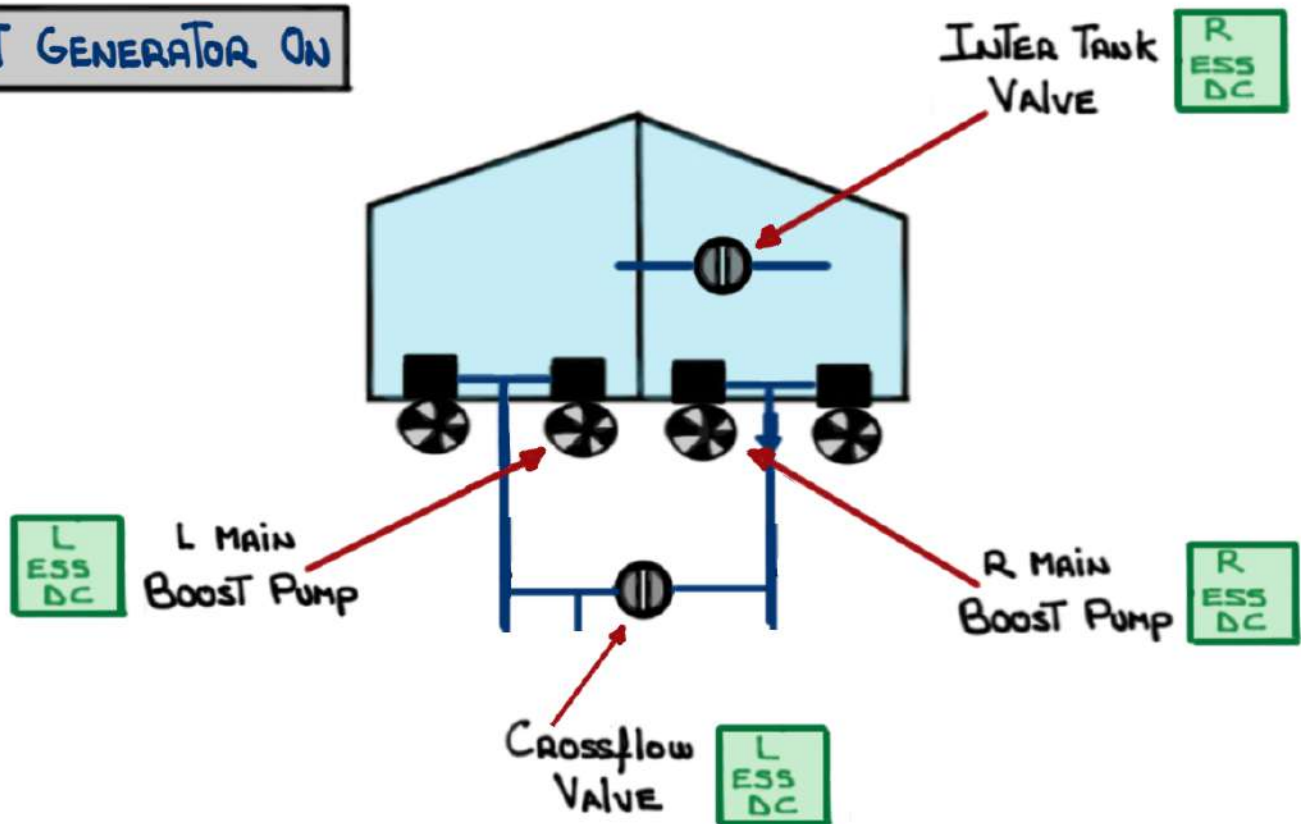

FUELING OPERATIONS

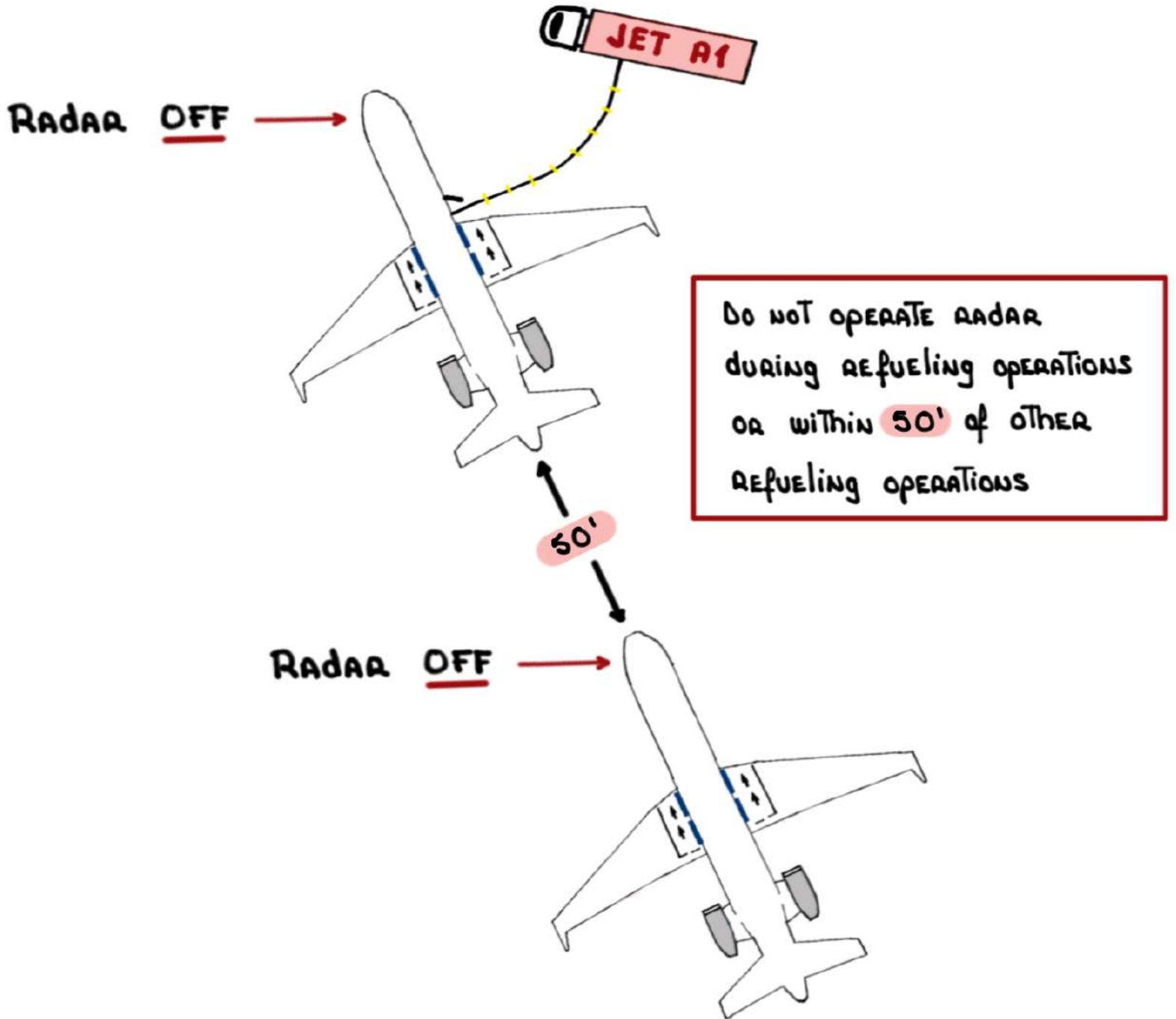

BEFORE REFUELING, ENSURE AIRPLANE IS BONDED
TO THE FUEL SOURCE

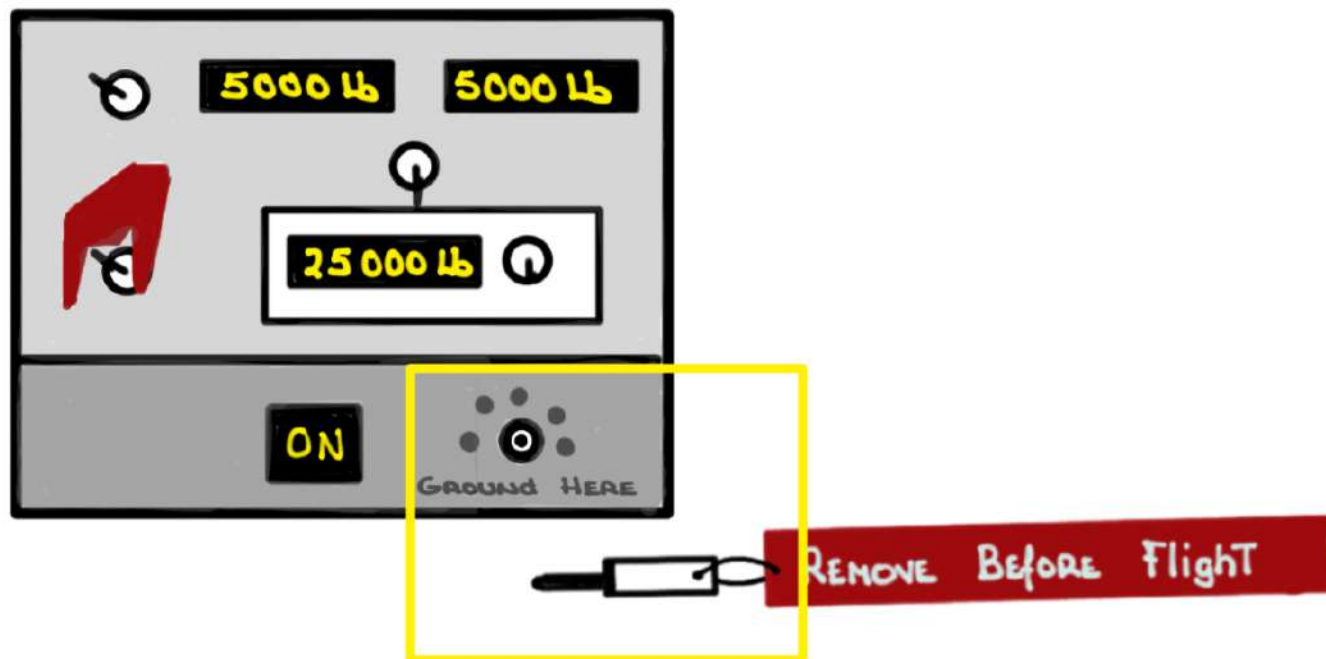

Grounding jack is **located** in The Ground
SERVICE CONTROL PANEL (GSCP)

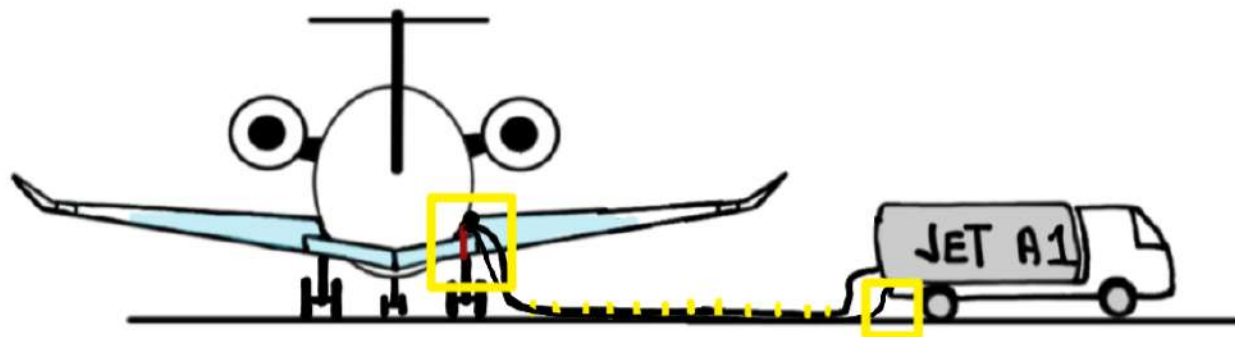

WATER CONTAMINATION/FUEL TANK DAMAGE PREVENTION MEASURES

- Biobor JF AVIATION fuel biocide TREATMENT:
 - * KILLS AND PREVENTS MICROBIAL GROWTH
 - * PREVENTS MICROBIAL CORROSION ISSUES AND FILTER PLUGGING
- FUEL TANK SUMPING AT CONSISTENT WATER DRAINING FREQUENCIES

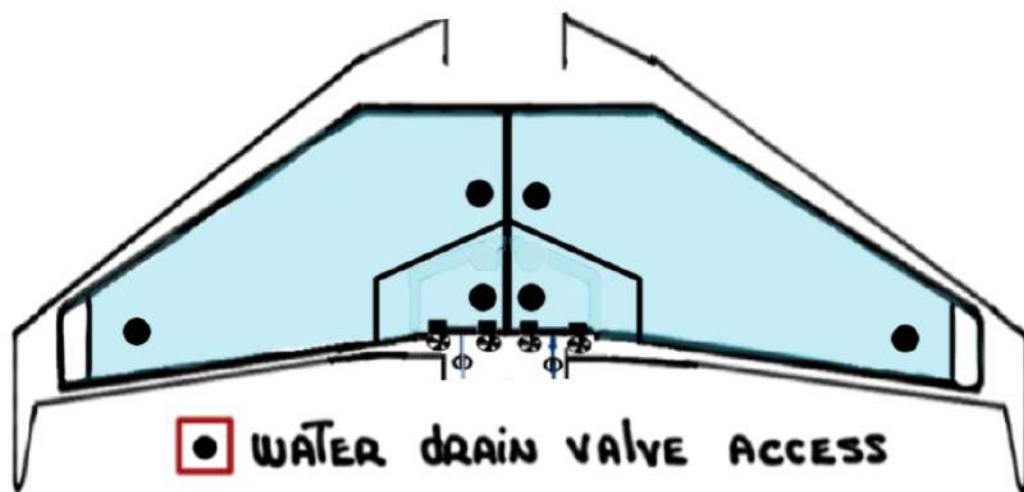

- FUEL QUALITY CHECK OF FUEL SOURCE PRIOR TO EACH REFUELING OPERATION

REMINDER: these system notes are intended for study purposes only. Always refer to official Gulfstream manuals and other approved references when operating your aircraft.

NOTE: these system notes are updated from time to time and what is posted on Code450.com will always be the most recent version.

Questions, comments or errors...please do send me an email:
ivan.luciani@gmail.com

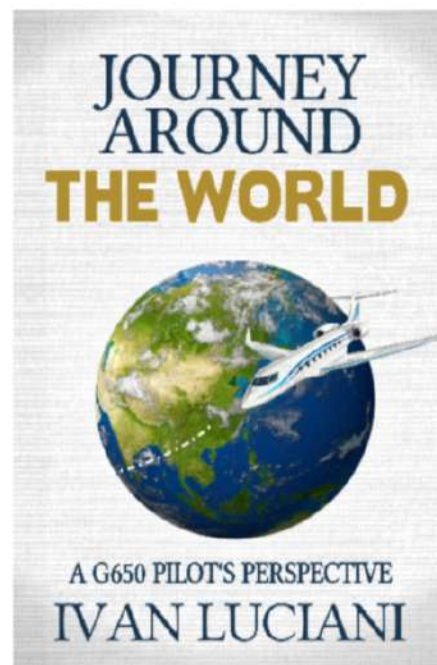
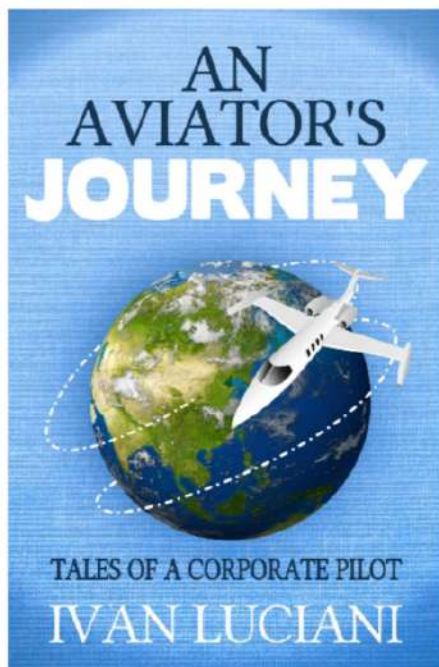

Thank you!