

# G600 PRESSURIZATION SYSTEM

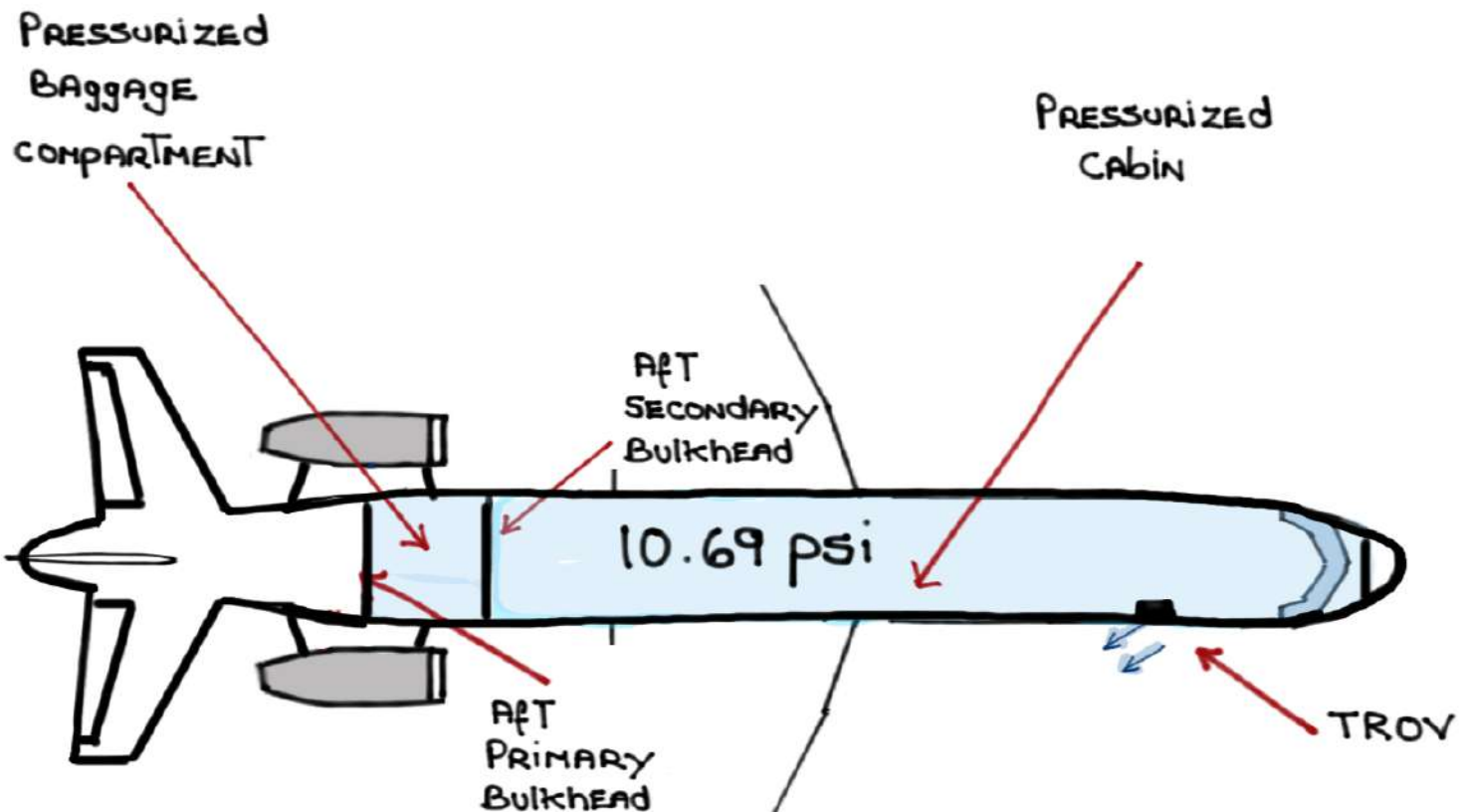

For study purposes only

THE PRESSURIZATION SYSTEM CONTROLS CABIN PRESSURE by MODULATING THE THRUST RECOVERY OUTFLOW VALVE (TROV) IN ORDER TO ACHIEVE AND MAINTAIN AN OPTIMUM CABIN PRESSURE OF **10.69** PSI AND A CABIN ALTITUDE OF **4,850'** AT FL**510**

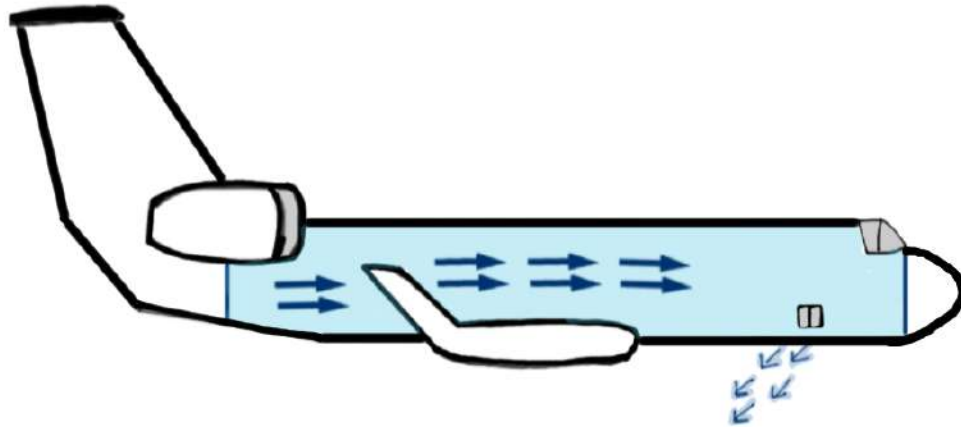

CABIN AIR EXITING VESSEL VIA:

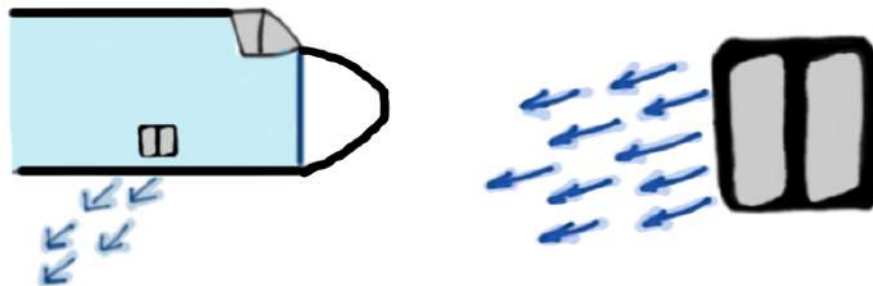

THRUST RECOVERY  
OUTFLOW VALVE  
(TROV)

IN ORDER TO ACHIEVE  
OPTIMUM CABIN PRESSURE

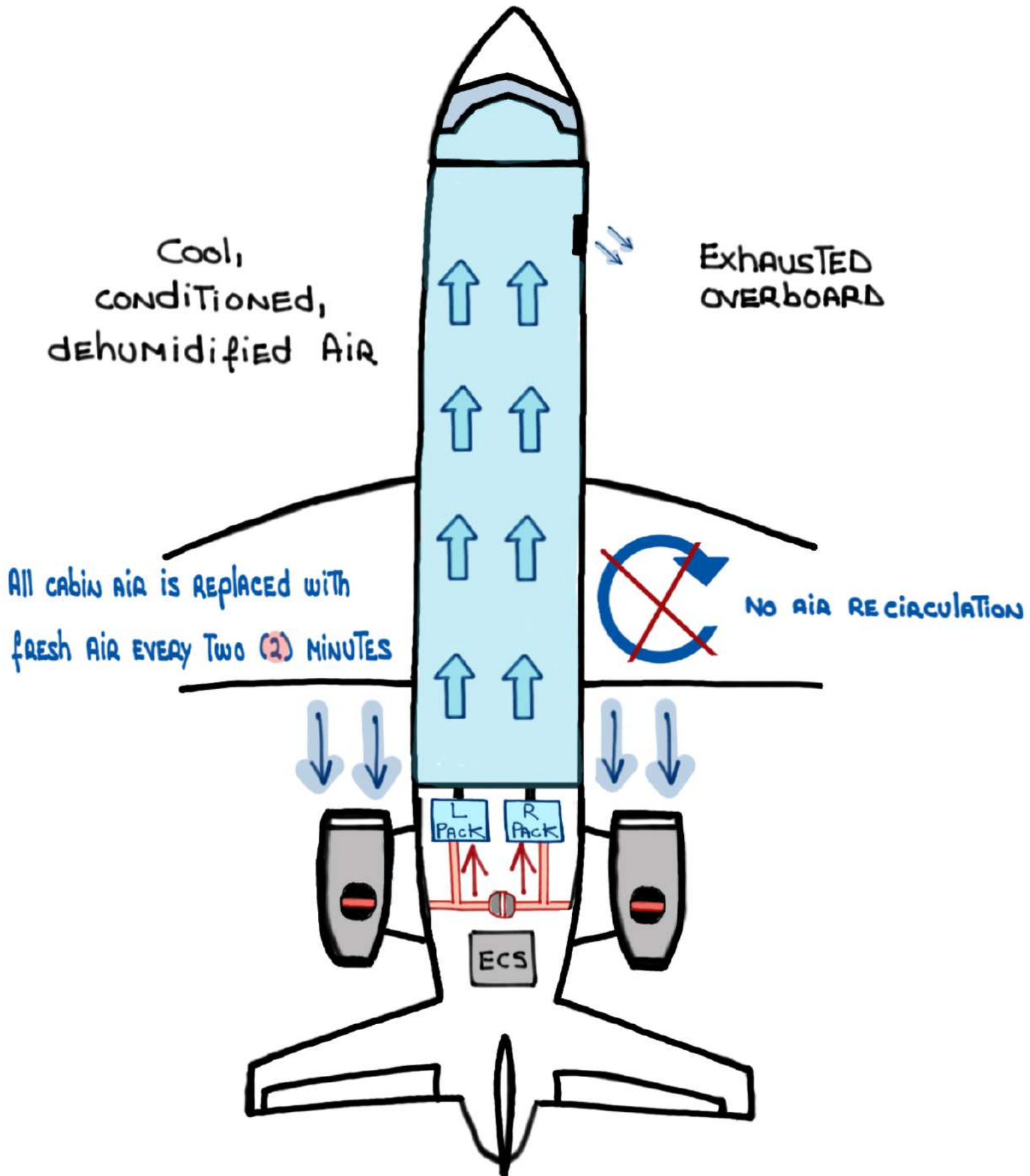

# THREE (3) OPERATIONAL MODES

Mode: AUTO 1 (2)  
SYSTEM Mode



Mode: SEMI 1 (2)  
SYSTEM Mode



# TWO (2) PRESSURIZATION MODES

PRESSURE PROFILE



PRESSURE PROFILE



# PSI Limits

FL 510

10.69 PSI

4,850' CABIN ALTITUDE

NORMAL

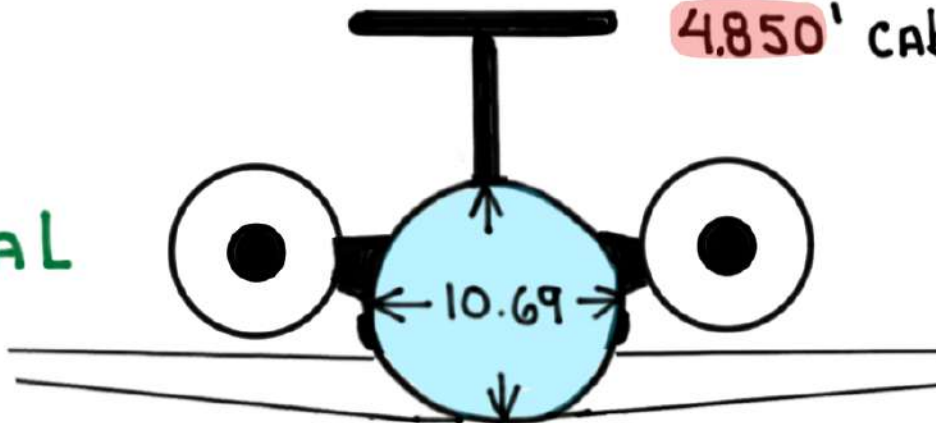

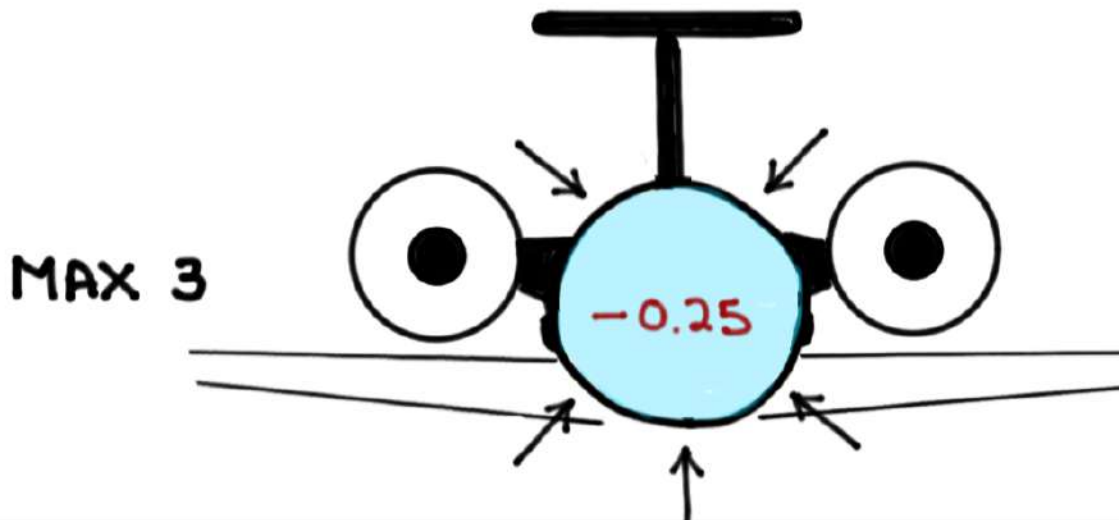
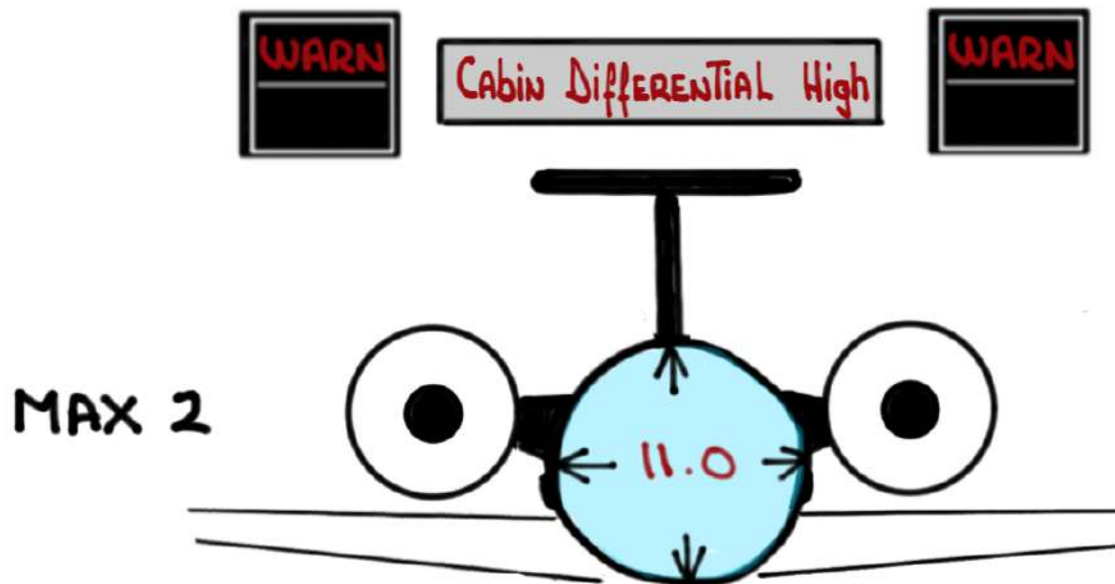
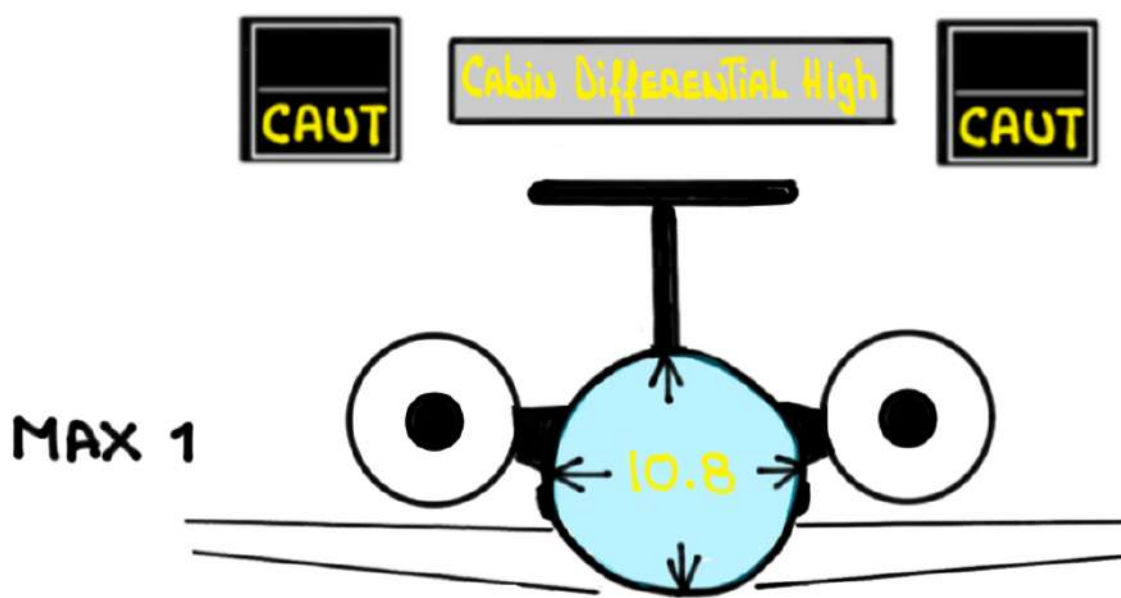

MAX 4

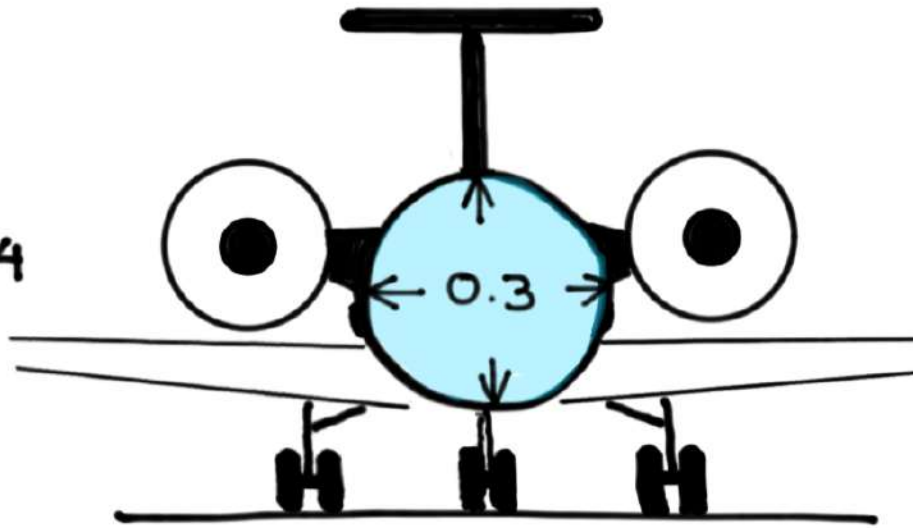

MAX  psi during TAXI, TAKEOFF AND LANDING  
SO AS TO ALLOW THE OPENING OF THE **EMERGENCY**  
**EXIT DOORS (EED)** AND MAIN ENTRANCE DOOR (MED)

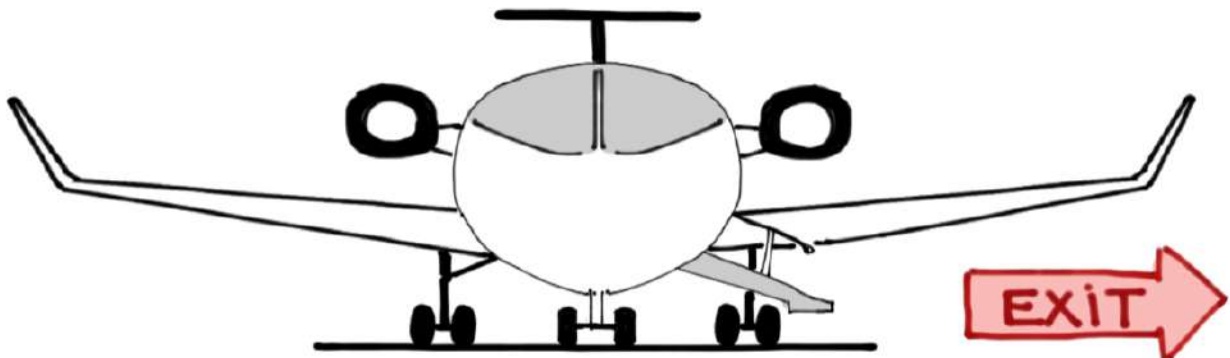
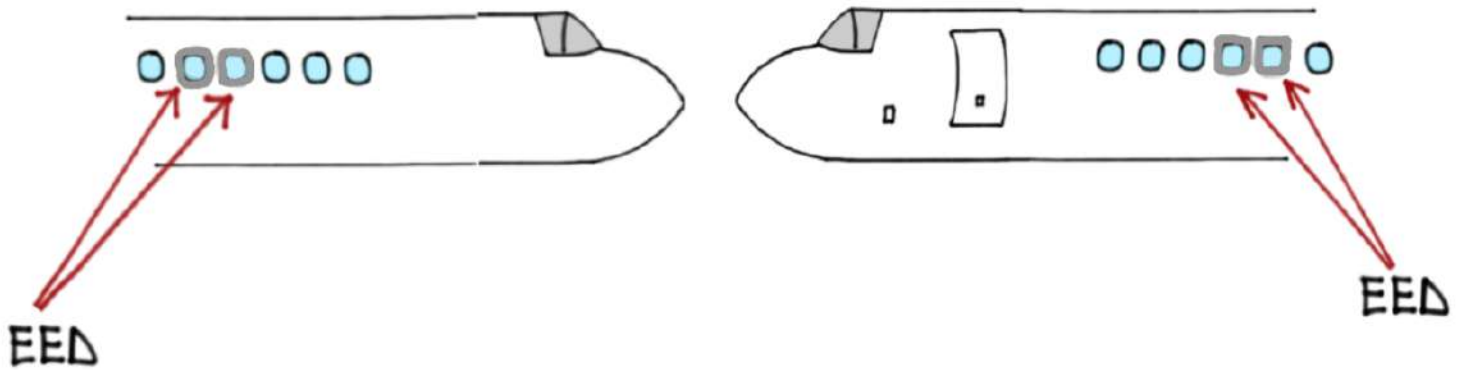

# CABIN PRESSURE CONTROL UNITS (CPCU)

- BRAINS of the PRESSURIZATION SYSTEM
- THE CPCUs ARE MICROPROCESSORS THAT MAKE ALL LOGICAL DECISIONS ASSOCIATED WITH PRESSURIZATION
- ONE (1) CPCU IN CONTROL AT THE TIME WITH REMAINING CPCU ON STANDBY
- ACTIVE AND STANDBY ROLES SWITCH AFTER LANDING  
WOW - **G** plus ONE (1) MINUTE
- THE CPCUs RECEIVE INPUT:

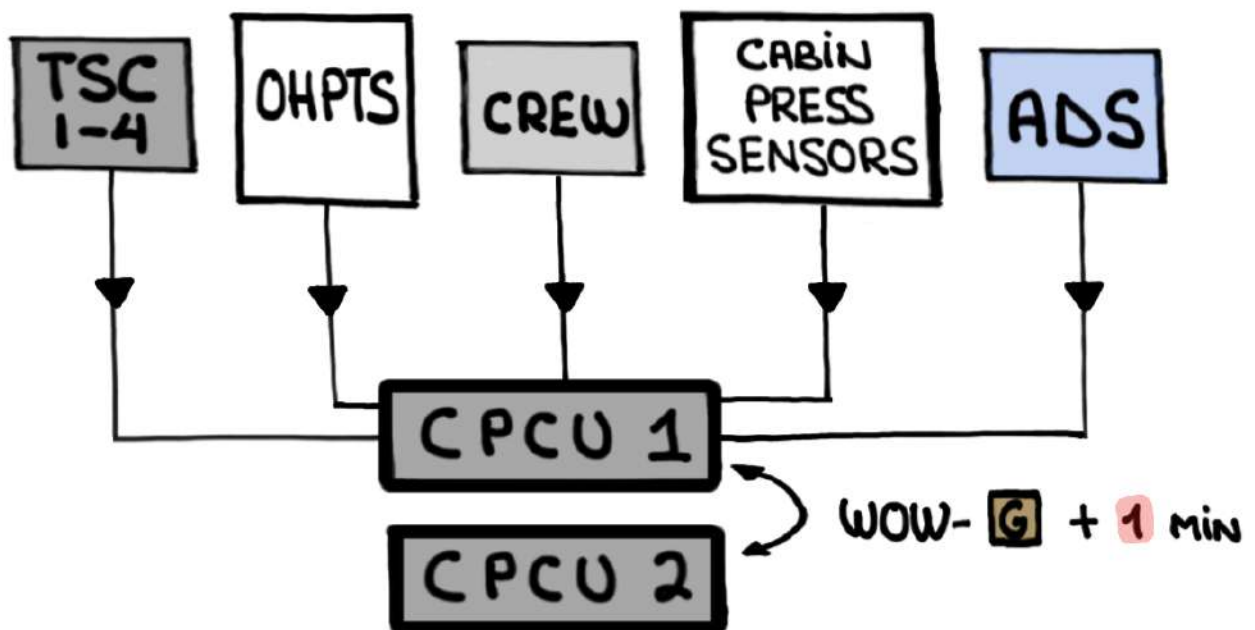

- **CPCU 1** **CPCU 2** ARE LOCATED BENEATH THE COCKPIT FLOOR
- CONTROL THRUST RECOVERY OUTFLOW VALVE when in

Mode: **AUTO 1 (2)**  
SYSTEM Mode

Mode: **SEMI 1 (2)**  
SYSTEM Mode

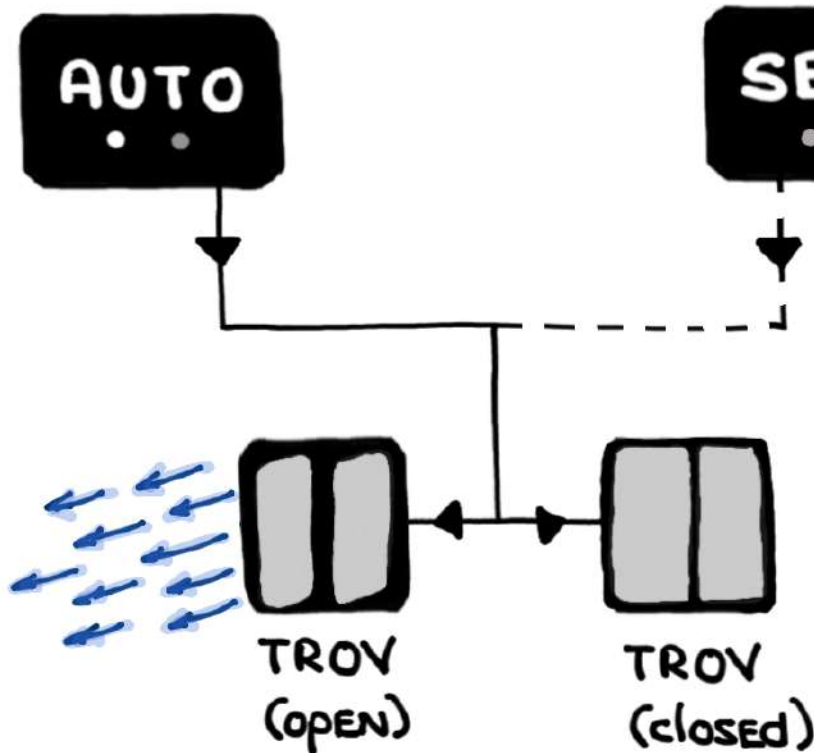

- REGULATE CABIN RATE OF CLIMB AND DESCENT by MODULATING THE TROV

- **CPCU 1** **CPCU 2** PROVIDE THE FOLLOWING INFORMATION AND DISPLAY IT ON OHPTCs:

CABIN ALTITUDE, CABIN DIFFERENTIAL PRESSURE AND CABIN RATE OF CHANGE



# CABIN PRESSURE ACQUISITION MODULE (CPAM)

- SELF CONTAINED UNIT LOCATED BENEATH THE COCKPIT FLOOR
- STANDALONE SOURCE OF CABIN PRESSURE INFORMATION
- **CPCU 1** **CPCU 2** COMPARE CABIN PRESSURE DATA WITH EACH OTHER



- ARBITRATOR: USED IF **CPCU 1** AND **CPCU 2** DISAGREE
- IF THEY DIFFER BY  $\geq 310'$  THEY THEN COMPARE EACH OTHER AGAINST THE **CPAM**

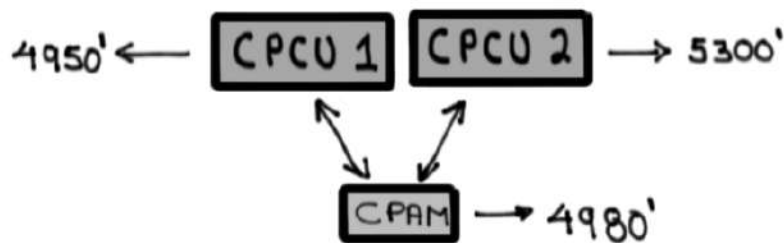

- $\geq 310'$  THAN THE **CPAM** CAUSES THAT CPCU TO FAIL

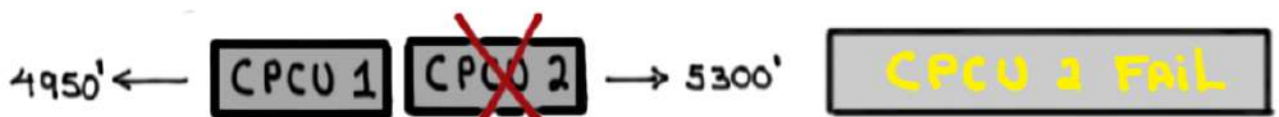

# THRUST RECOVERY OUTFLOW VALVE (TROY)



- The TROY is flushed MOUNTED ON LOWER SIDE OF RIGHT FORWARD FUSELAGE
- Butterfly PLATES OPEN/CLOSE TO MANAGE ESCAPE OF CABIN AIR
- DRIVEN by 1 of 3 28 VDC MOTORS AT A TIME

Mode: AUTO 1 (2)  
SYSTEM Mode

Mode: SEMI 1 (2)  
SYSTEM Mode

- A MANUAL MOTOR CONTROL UNIT (MMCUC) allows for MANUAL CONTROL OF THE TROY

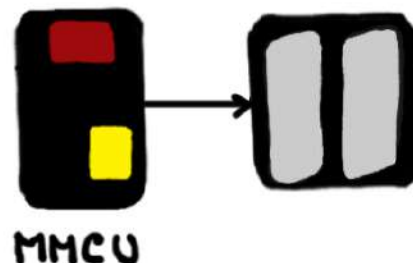

# PRESSURE RELIEF VALVE (PRV)

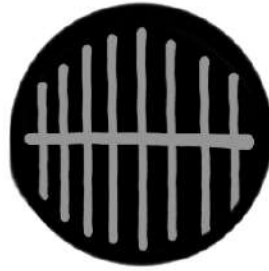

- THE PRV IS LOCATED JUST ABOVE THE TROV
- THE PURPOSE OF THE PRV IS TO PROTECT THE AIRCRAFT FROM DAMAGE DUE TO EXCESSIVE POSITIVE OR NEGATIVE PRESSURE

## ① POSITIVE DIFFERENTIAL PRESSURE RELIEF:

TWO (2) METERING SECTIONS

1<sup>ST</sup> CHAMBER OPENS AT:

2<sup>ND</sup> CHAMBER OPENS AT:

Cabin Differential High

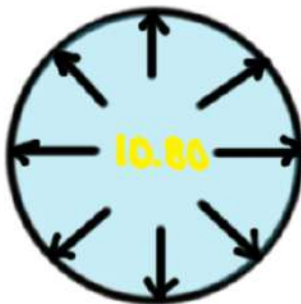

PSI

Cabin Differential High

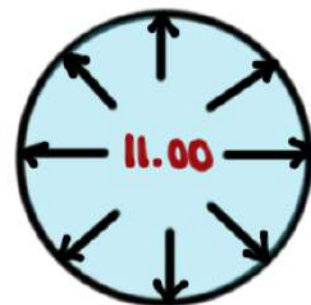

## ② Negative Differential Pressure Relief:

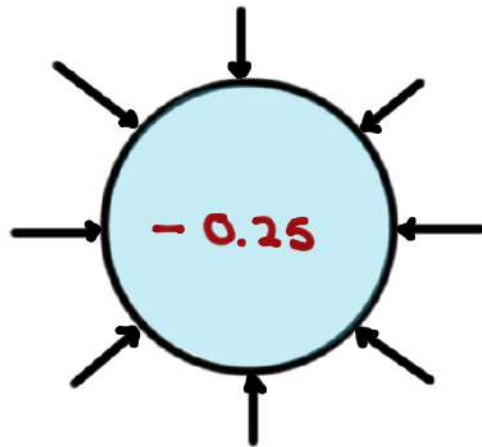

NO CAS MESSAGE

## ③ Ground Pressurization Limiting:

PRV opens sixty (60) SECONDS AFTER TOUCHDOWN

- INDEPENDENTLY SENSES CABIN PRESSURE USING AIRCRAFT STATIC PORTS LOCATED ON THE RIGHT SIDE OF THE FUSELAGE

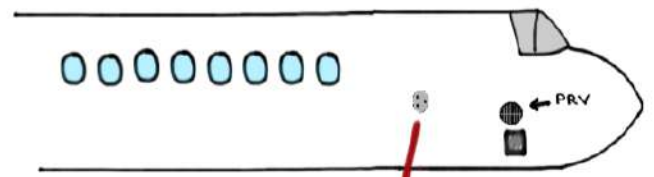

FEEDS PRV  
10.8 PSID  
Relief

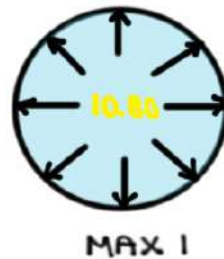

FEEDS PRV  
11.0 PSID  
Relief

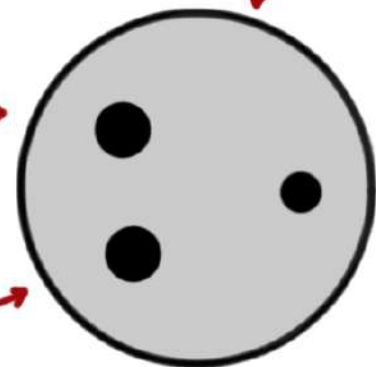
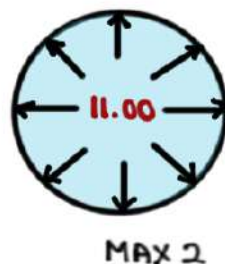

# AUTO MODE

Mode: AUTO 1  
SYSTEM Mode



Mode: AUTO 2  
SYSTEM Mode



- NORMAL MODE of OPERATION (fully AUTOMATIC)
- **CPCU 1** **CPCU 2** CONTROL PRESSURIZATION BASED ON PRESSURIZATION SCHEDULE
- **CPCU 1** **CPCU 2** RECEIVE INPUT FROM FMS DATA
- PRESSURE PROFILE MODES ARE AUTOMATIC



PRESSURE Profile

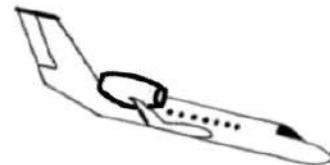

PRESSURE Profile



- PRE-PRESSURIZATION TO 0.25 PSI (APPROX. LFE - 500') INITIATED IF DOOR CLOSED AND ANY OF THE FOLLOWING OCCUR:
  - 1) TAXI SPEED > 9 KNOTS, OR
  - 2) THROTTLES ADVANCED  $\geq 15^\circ$  THRUST LEVER ANGLE (TLA), OR
  - 3) MANUALLY SELECTED BY THE CREW

**CAUTION** IF RETURNING TO THE RAMP Deselect **Flight** IN ORDER TO DEPRESSURIZE THE CABIN PRIOR TO OPENING THE MAIN DOOR

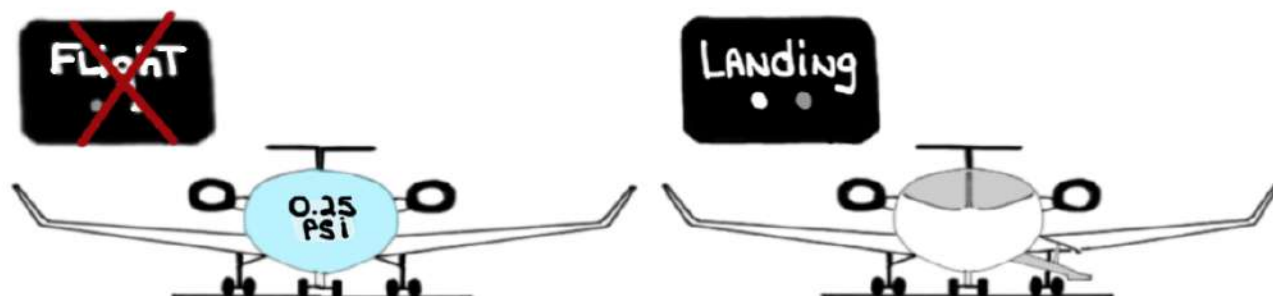

- CABIN RATE OF CLIMB AFTER TAKEOFF: 500 fpm
- DURING DESCENT AS THE AIRCRAFT CROSSES 1,000' BELOW CRUISE ALTITUDE PRESSURE PROFILE CHANGES FROM:

**Flight** To **Landing**

- If the aircraft levels off for 3-6 minutes  $\geq$  FL 250  
The Pressure Profile changes from:

LANDING To FLIGHT

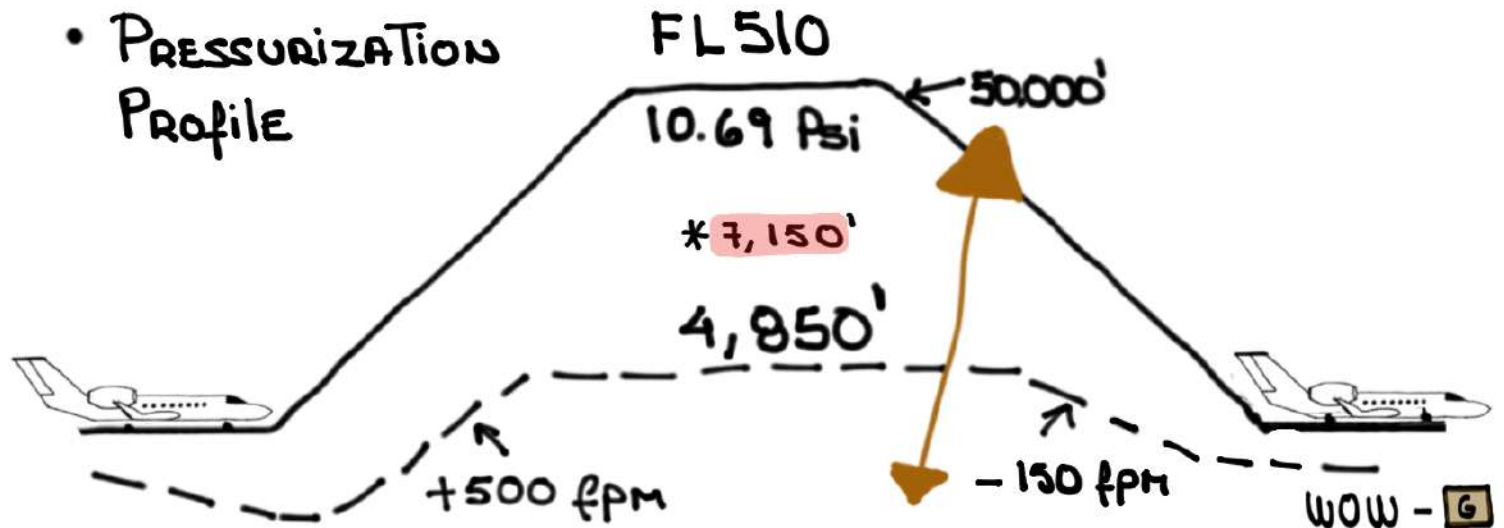

Taxi out  
> 9 knots

1,000' below  
cruise altitude

FLIGHT

LANDING

LFE - 500'

LFE - 250'

@ 300 fpm

@ 150 fpm

$\Delta P$  0.25 Psi

\* 7,150' w/LFE > 10,000'

WOW - G:

- ① Cabin climbs @ 500 fpm for one (1) minute to depressurize
- ② PRV opens sixty (60) seconds after touchdown

# SEMI MODE

Mode: SEMI 1

SYSTEM Mode



Mode: SEMI 2

SYSTEM Mode



- ALTERNATE NORMAL MODE OF OPERATION (SEMI AUTOMATIC)
- SEMI MODE USED WHEN:

- FMS DATA NOT AVAILABLE OR IS INVALID
- DIRECTED BY THE CHECKLIST
- CREW DISCRETION  $\left\{ \begin{array}{l} \text{QFE OPERATIONS} \\ \text{CREW WANTS MORE CONTROL} \\ \text{OVER THE SYSTEM} \end{array} \right.$

- CREW ENTERS DATA VIA TSC 1-4

MENU → SYSTEMS → CPCU TAB



- PRESSURE PROFILE MODES ARE AUTOMATIC



PRESSURE PROFILE



PRESSURE PROFILE



- LANDING FIELD ELEVATION (LFE) LIMITED TO < 10,000' \*  
IN SEMI MODE

Mode: SEMI 1 (2)

SYSTEM Mode



PRESSURE PROFILE



\* EXCEPT IN AN EMERGENCY

# MANUAL MODE

If ~~CPCU 1~~ ~~CPCU 2~~ ARE INOPERATIVE THE CREW CAN STILL CONTROL THE PRESSURIZATION SYSTEM

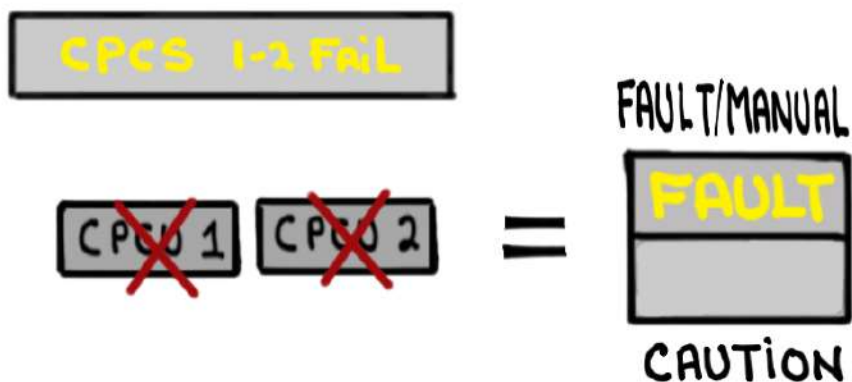

- THE CREW SELECTS MANUAL MODE IN ORDER TO MANUALLY CONTROL THE TROV AND CLIMB, MAINTAIN, AND DESCEND THE CABIN

## Cabin Pressure Manual

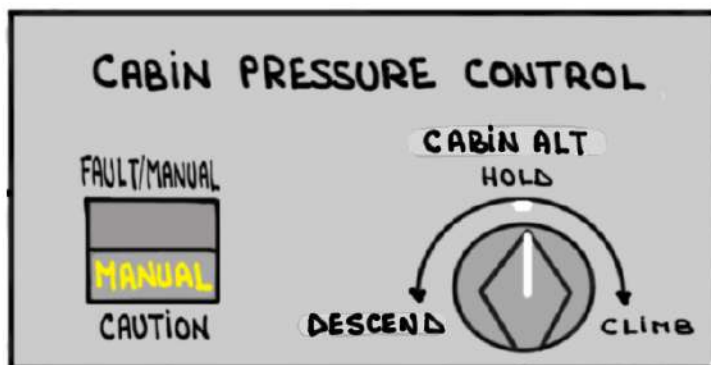

- The **CPAM** provides data

## Cabin Pressure Manual

Cabin Altitude  
Cabin Rate  
Cabin Differential

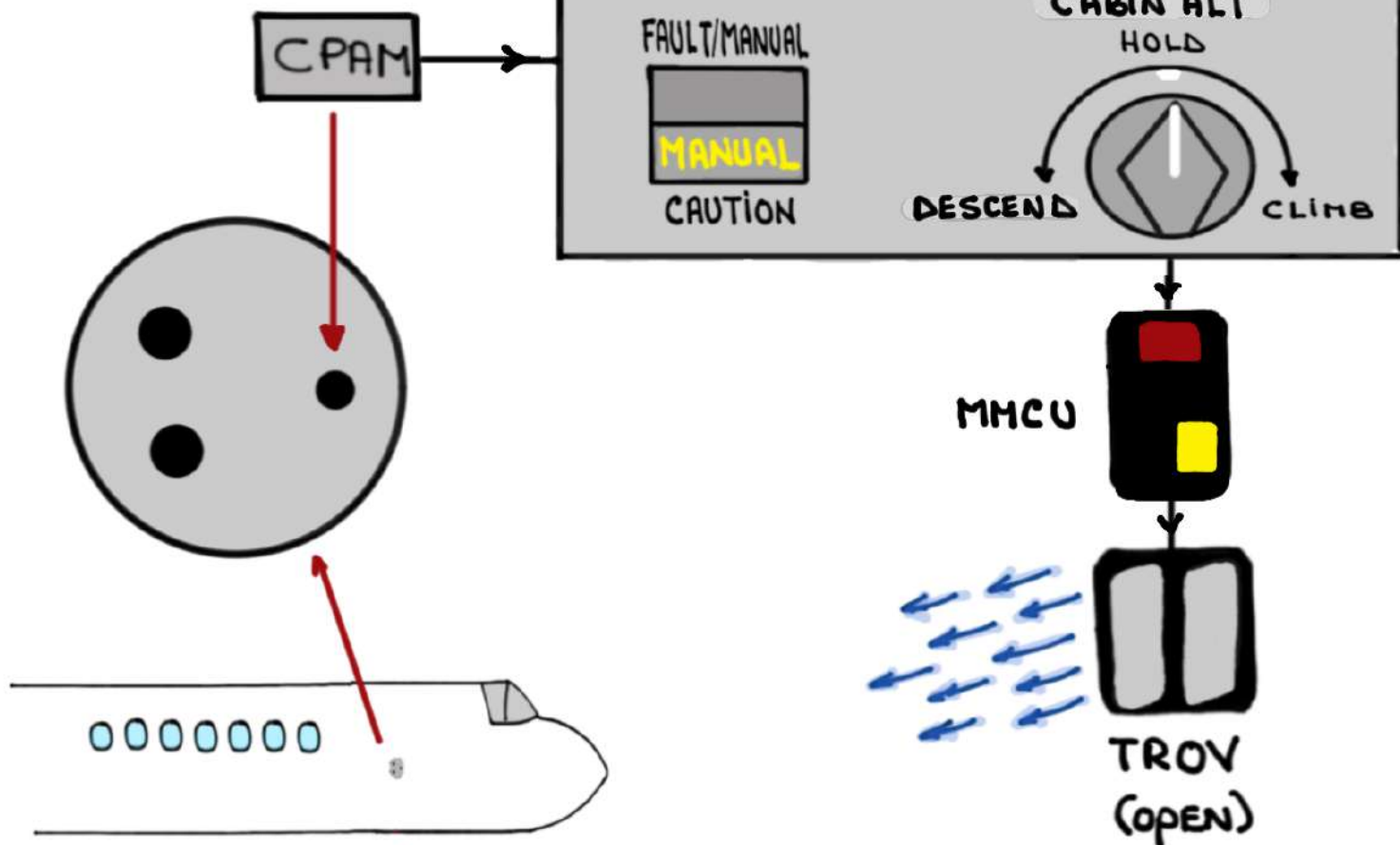

- CHANGES IN ENGINE THRUST AFFECT CABIN AIRFLOW. THIS CAUSES VARIATIONS IN CABIN PRESSURE AND RATES OF CHANGE

- MANUALLY CONTROLLING CABIN PRESSURE REQUIRES CONSTANT MONITORING AND CREW COORDINATION

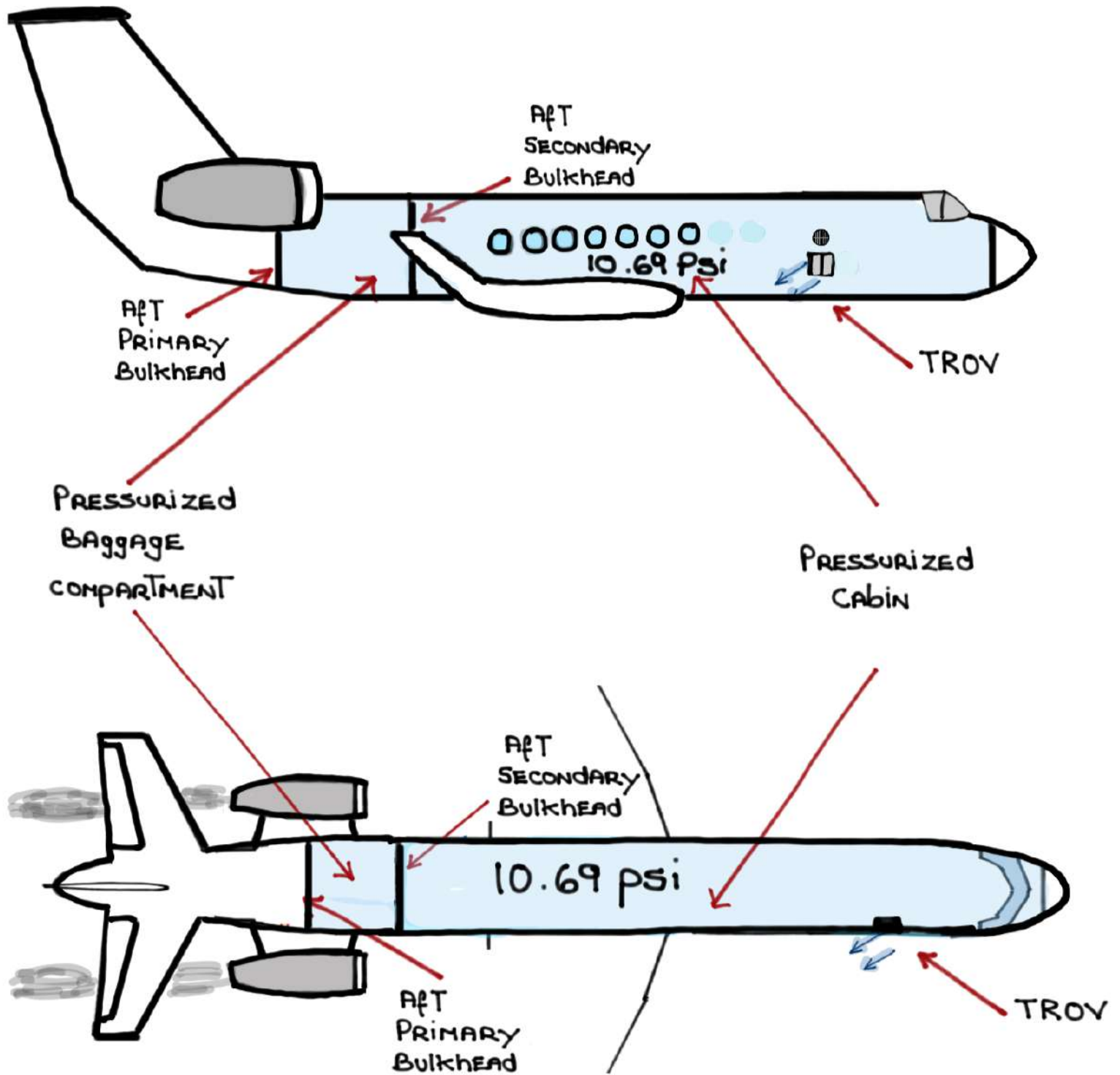

# ROTOR BURST/PRESSURIZATION

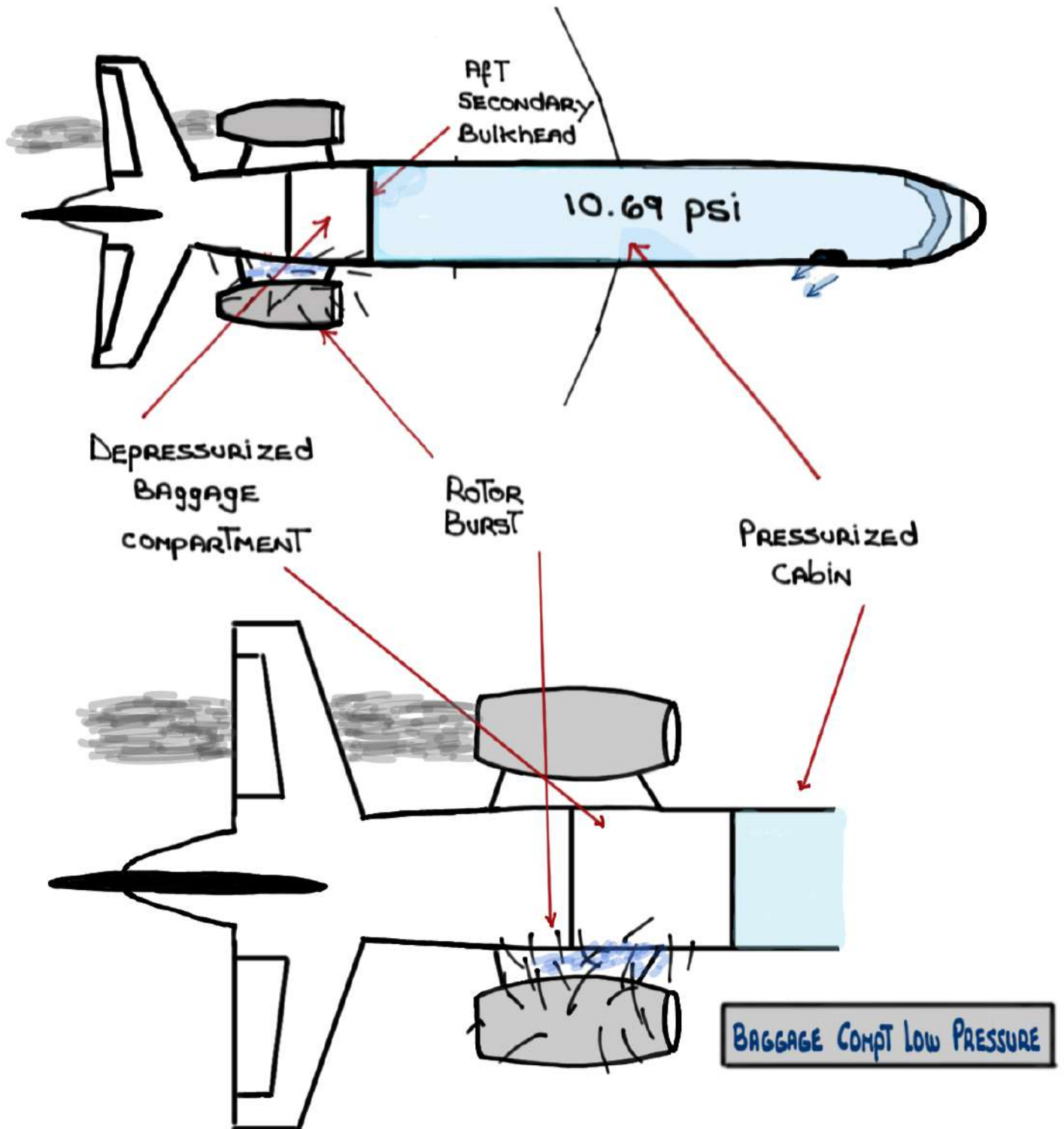

The physical location of the TROV, and the availability of the secondary pressure bulkhead, ensures that cabin pressurization is not affected



# CABIN PRESSURE LOW TRIP POINTS

<u>Mode</u>	<u>LANDING FIELD ELEVATION</u>	<u>Cabin ALTITUDE</u>
FAULT/MANUAL  CAUTION	N/A	 8,000'

Mode: AUTO 1 (2)  
System Mode



> 14,000'

≥ 15,500'

9,500' - 14,000'

≥ 14,500'

Mode: SEMI 1 (2)  
System Mode



7,500' - 9,500'

≥ 10,000'

SEA LEVEL - 7,500'

≥ 8,000'

# EMERGENCY DESCENT MODE (EDM)

Autopilot ON

AIRCRAFT ALTITUDE  $\geq$  FL400

**Cabin Pressure Low** CAS MESSAGE

- ① AUTO THROTTLES ENGAGE if DESINGAGED
  - THROTTLES RETARD to idle
  - FMA POWER display on PFD → **FLCH**
- ② GP LATERAL Mode - deselected
  - FMA LATERAL display on PFD → **EDM**
  - COMMAND **90°** LEFT TURN
- ③ GP VERTICAL Mode - FLCH
  - FMA VERTICAL display on PFD → **IAS** with ASEL
- ④ GP SPEED mode - MAN
  - VMO (**340** KNOTS) displays on SPEED window
- ⑤ ALTITUDE - **15,000'** in PRESELECT window
- ⑥ SPEED BRAKES EXTEND AUTOMATICALLY AS SPEED INCREASES ABOVE **0.91M/315** KCAS (HANDLE DOESN'T MOVE)

## - FLIGHT MODE ANNUNCIATOR (FMA)



## - GUIDANCE PANEL (GP)

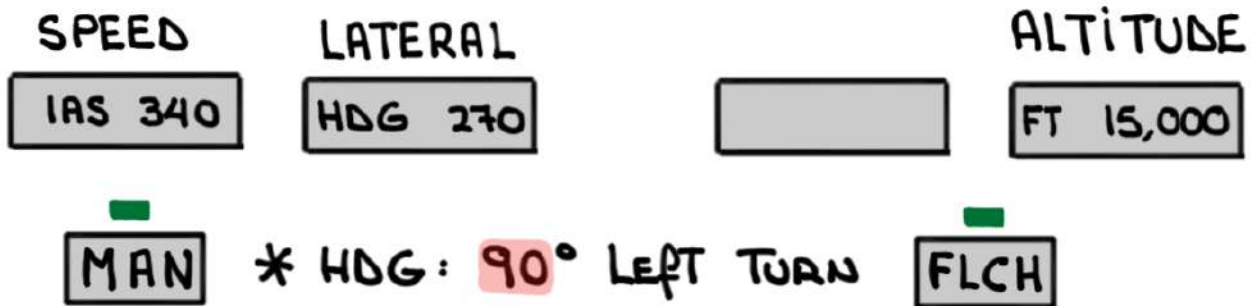

## - LEVEL OFF

- FMA VERTICAL display on PFD → ASEL → ALT
- FMA Speed display on PFD → 340 → 250
- SPEED BRAKES RETRACT AT 270 KNOTS

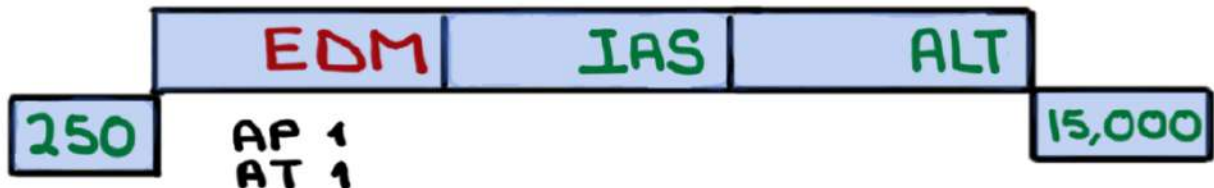

## - CANCELING EDM:

- DISCONNECT button ON SIDESTICK, OR
- Deselect AP ON GP



# Oxygen Requirements / Operations

Above 41,000' ONE pilot MUST BE ON oxygen - FAR 91

CREW AND PASSENGER MASKS NOT APPROVED FOR USE  
ABOVE 40,000' CABIN ALTITUDE

ABOVE 35,000' ONE pilot MUST BE ON oxygen if THE  
OTHER pilot LEAVES THE cockpit - FAR 91

PASSENGER MASKS will NOT provide sufficient oxygen  
ABOVE 34,000' CABIN ALTITUDE

ABOVE FL250 CREW MASKS MUST BE IN THE quick  
donning position which allows donning within  
five (5) SECONDS

AUTOMATIC deployment of PASSENGER oxygen MASKS  
AT 14,750' ± 250' (15,750' ± 250' with ALT SELECT)



REFER TO AFM 01-35-10 TO DETERMINE REQUIRED oxygen  
QUANTITY FOR DEPARTURE

**REMINDER:** these system notes are intended for study purposes only. Always refer to official Gulfstream manuals and other approved references when operating your aircraft.

NOTE: these system notes are updated from time to time and what is posted on Code450.com will always be the most recent version.

Questions, comments or errors...please do send me an email:  
[ivan.luciani@gmail.com](mailto:ivan.luciani@gmail.com)

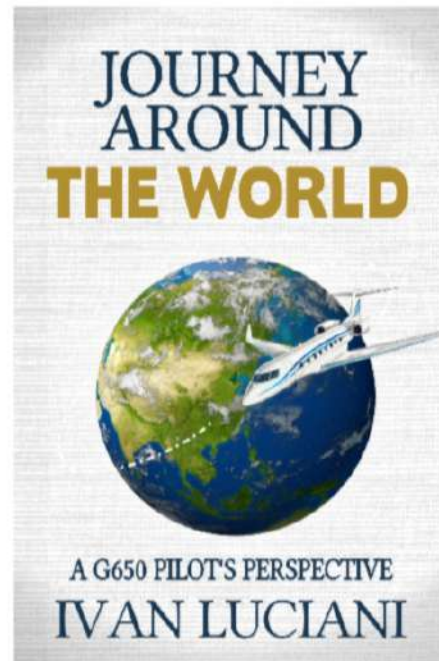
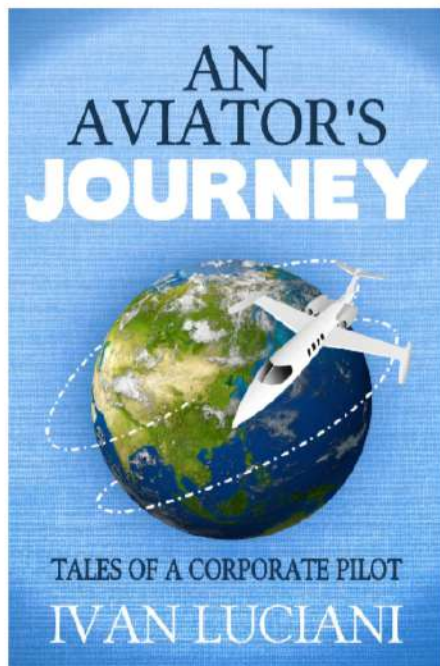

Thank you!